

Standard Version

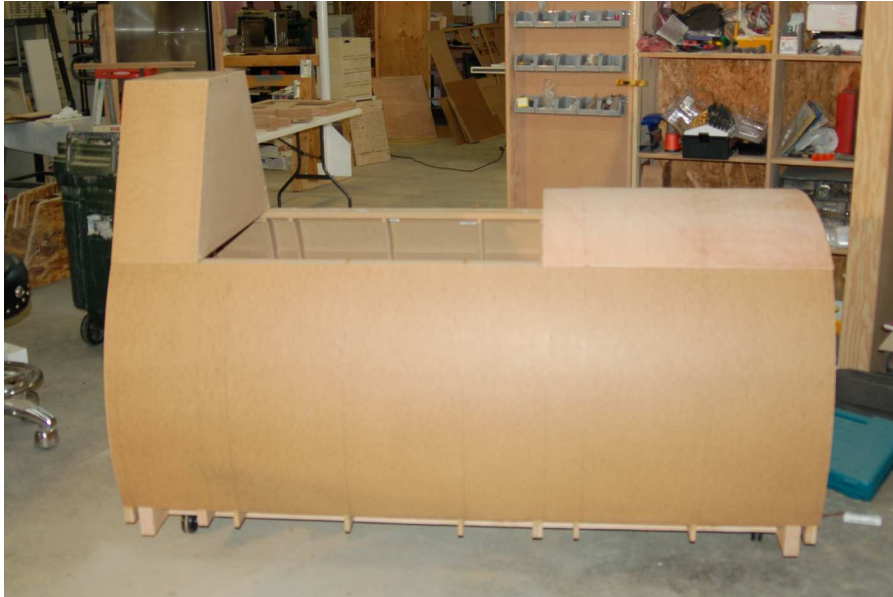

Windscreen & Canopy Version

Introduction

First of all I'd like to thank you for purchasing this DIY Cockpit Project. I hope you get as much enjoyment out of building and simming in it as I did designing and building it myself.

This first project is optimistically called the "Series 1" cockpit. It's my hope that there will more DIY Cockpit designs to cover other general types of aircraft.

As a first endeavor, I look forward to getting feedback from you and your fellow builders. There will be a mailing list set up to support the project and a Wiki-like site set up so you can trade tips and feature enhancements among yourselves. I encourage participation in this as user end-user modifications have the potential to make a good design even better.

One thing I've learned during the construction of this project is that nothing is 100% perfect. You'll run into things like the seams won't mate completely, etc. I've done my best to make sure that all the parts fit and things line up, but remember, we're working with wood. There will be differences between what I show and what you end up with. It's not the end of the world. ☺ Wood putty and paint can hide any number of sins. Don't worry about it.

If you have any questions or problems, please don't hesitate to send me an email – my address is geneb@deltasoft.com.

I'd like to thank Robbi Hommel for being a great sounding board, even if he didn't know what I was up to most of the time. ☺

I'd also like to thank David Allen for putting up with my stupid Inventor questions until I finally got a grip on what I was doing.

The Do it Yourself Cockpit Project – Series One

To all on the Simpits-Tech list at simpits.org, thanks for putting up with my constant harping about this project! You guys are the best!

On to the good stuff....

Chapter One - Tools...

Here's a list of some basic tools that you're going to need in order to build this project. They're in no real order and frankly, they occur as I think of them. ☺

1. A Jig saw with suitable blades for cutting MDF or OSB, depending on what your material of choice is going to be for the cockpit. Pawn shops are a good place to find these – especially the heavy duty (physically pretty heavy as well) ones. The heavier the Jig Saw, the better cut you'll get out of it. The weight helps counteract the reciprocating action of the blade and reduces the tendency of the saw to “jump”.
2. A good electric screw driver. You will go out of your mind if you try driving all the needed screws by hand. Trust me on this. Two models I use are the Ryobi Lithium 4V driver (Model # HP41L) and the Skil iXo² Lithium Ion driver. Both are good tools and get the job done. Make sure you've got the regular PH2 phillips tip as well as the larger PH3 tip. The PH3 tip is used in the ¼”x20 flat head screws that are used to attach the end caps. A PH2 is too small to drive them “properly”.
3. A set of good drill bits. Since you're not going to be doing any serious metal drilling (at least for the parts I'm showing you), any cheap set will get the job done. Most of the holes you're going to be drilling are ¼” for bolt holes and 5/16” holes for the places where you'll use the ¼” T-Nuts. You'll also be drilling quite a few 7/64” pilot holes for #8 screws. This of course leads to...
4. A good drill. I prefer a battery powered one – I get more flexibility out of it and no cord to get in the way. I personally use a Makita 9.6v as well as a Black & Decker 18v Fire Storm. Pretty much any good drill will serve your needs though.

The Do it Yourself Cockpit Project – Series One

5. A 7/16” socket wrench. All the ¼”x20 hex head bolts need this size.
6. A device called a “Micro Stop”. This is an aircraft metalworking tool that is used to create countersinks for flat head rivets. In this project it’s used to countersink in wood for screw heads. You can’t swing a bat without hitting a pile of these things on eBay. They’re pretty inexpensive and you can get the two bits you need online from Aircraft Spruce. The two cutters you’ll need are the ¼” and #8 screw cutters. (Aircraft Spruce Part #s 12-00881 and 12-00947 respectively)



Here’s a typical Micro-Stop

- The reason I specify these is that by using a micro-stop, you can control the depth of the countersink and that’s very important, especially if you’re a novice woodworker. The cutters are 100 degree while all the fasteners we’ll be using are 82 degree, but it works out just fine.
7. A circular saw. Any 7-1/2” circular saw will work. If you don’t have one already, check out the local pawn shops. You can usually get a good deal on a high quality saw that way. (Rob has gotten *steal* on a magnesium chassis worm drive saw that way.)
 8. A table saw. You knew this was coming, didn’t you? ☺ Seriously, a table saw is literally required (unless you’re some kind of god with a circular saw) in order to make the canopy and windscreen frame options. Unfortunately, this doesn’t mean a table-top table saw. They don’t have the depth of throat required to accommodate the windscreen and canopy frame parts that need to have angles cut in them. However, this is a GREAT excuse to get that full sized table saw you always wanted, right? ☺ Again, hit the pawn shops – you’d be surprised what you can find there.
 9. A Wixey Digital Angle Gauge. If you’re going to make the windscreen and canopy for your cockpit, you MUST be able to set the blade angle of the table saw to 23.5 degrees. This is the best way I’ve found to do this. This little thing paid for itself the first time I used it. This is an item that Rockler sells – <http://www.rockler.com> is the address of their site. Be warned though, therein lies Much Tool Porn. You’ve been warned. ☺
 10. Self-Centering pilot drills. These little gadgets come in really handy when installing hinges or brackets that have pre-drilled holes. Nothing makes a person madder than getting the pilot hole just a bit off center and having the screw ruin the alignment of what you’re working on. This is a nice to have – again, they’re available at Rockler or pretty much any other fine vendor of woodworker Tool Porn.

The Do it Yourself Cockpit Project – Series One

11. A standard #8 wood countersink. If you're building the windscreen, there are a few places where you'll need to create a deeper than usual countersink.
12. A router. If you've purchased the router templates, you're going to need a good router and a router table. You'll also need a ¼" flush trim bit with a ¼" shank. This bit is unusual because the bearing is also ¼", which is required in order to navigate the interior slot cuts on the templates. MLC's Woodworking sells these - \$9.50 for the 1" version (MLCS P/N 5499). This cutter or one exactly like it is required in order to use the router templates. Any bit with a bearing size of greater than ¼" won't fit.
13. A good Combination Square. You'll use this to draw centerlines along parts. It's a pretty slick technique for those that haven't done it before.



14. Last but not least, you are probably going to want to get yourself a Pin Nailer. This is an air-powered tool that you can use to tack together assemblies as well as attach the skin. The model that places like Harbor Freight Tools carry is pretty basic and will only set you back about \$30, not including the air compressor you'll need. Check out the local pawn shop for a good second hand compressor. The smaller "pancake" style will be perfectly adequate for the nailer.
15. A small mallet that has a two sided head – one side is made of rubber; the other is made of a hard plastic. This will come in handy when you're installing the ribs.

Please note that power tools will do their very best to at least maim you the instant that you stop paying attention. Always pay attention to the warnings given about the tools you're using and always and I mean ALWAYS wear safety glasses!

Chapter Two - Bill of Materials

...or “Oh my god, what have I gotten myself into?”

Here’s a list of the basic materials you’ll need in order to create the parts needed for your cockpit. Note that I will refer to both OSB (Oriented Strand Board) and MDF (Medium Density Fiberboard) interchangeably throughout these instructions. The plans were created so that you could use either or both of those primary materials for the cockpit, depending on your budget.

1. __ 6 4’x8’ sheets of either ½” MDF or 7/16” OSB. If you’re really careful, you can get by with 5 sheets by carefully optimizing the material use. The last sheet is used for the center section and the remainder of that sheet is ripped down into stringers.
2. __ 2 4’x8’ sheets of 1/8” Tempered Hardboard. This is used for the skins as well as the instrument panel.
3. __ 90 ¼”-20 T-Nuts. Yes, **90** of them. They’re used throughout the cockpit in order to help make assembly (and disassembly!) much easier. I strongly suggest you buy these in bulk if you can. Your local Ace Hardware or Big Orange Retail Giant should carry them, but they’re typically about .30 each there. What would you rather do, buy a box of 100 from BoltDepot.com for about \$7, or spend \$27 on 90 of them from your local hardware store? 😊
4. __ 7 or 11 #10-24 T-Nuts. These are used when you mount the instrument panel. If you’re building the windscreen option, you’ll need 7 for the panel, if you’re not building the windscreen; the other panel requires 11 T-Nuts to mount.
5. __ 53 ¼”-20, 1” Flat Head Screws. These are used to attach the end caps and the upper section caps.
6. __ 3 ¼”-20, 1-1/2” Flat Head Screws. These are used in the upper section caps.
7. __ 6 2-1/2” wide hinges with removable pins. 4 of them are used on the end cap doors, 2 on the monitor deck if you’re building that. (only for the windscreen builders)
8. __ 1 1-1/2” wide piano hinge. This is only for those building the canopy. I *strongly* recommend that you purchase one that you can easily remove the hinge pin from. Aircraft Spruce carries these in 36” lengths for about \$6. You can substitute 3 2-1/2” hinges if you like.
9. __ 10 ¼”-20, 3.5” hex head bolts (5 on each side are used to mate the sides to the center section)

The Do it Yourself Cockpit Project – Series One

10. __ 4 3” castor wheels. You can use larger wheels if you’ve got them, but I would recommend against using anything smaller. The larger wheel helps when moving the cockpit around and the extra height is handy if you decide to use the Jentron Gimbal (http://www.geneb.org/pitkit/jentron_mk2/).
11. __ 16 ¼”-20, 1” hex head bolts (used for attaching the wheels to the center section).
12. __ 26 ¼” flat washers. Used in various places.
13. __ 1 box (minimum of 100) #8, 1-1/4” flat head wood screws. You’ll use these mostly to attach the decking to the 2x4 framing for the base of the cockpit.
14. __ 5 2x4, 8’ long. These are used for framing the left, right and center sections.
15. __ Scrap ¾” Plywood – this will be used to build the two 5” x 23-7/8” caster supports for the main base. The 5” width can be fudged a bit if you can find yourself a 10” wide x 24” long scrap. You should be able to buy a small 24x24 sheet of ¾” AC plywood at your local home center if you don’t have any scraps available.
16. __ 8 1” #6 flat head screws. Used to hold the end ribs in place for the cockpit sides.

Chapter Four - Cockpit Components

There are 34 basic part shapes used to build the Series One cockpit, not including “stock” material like 2x4s and cut to size stringers. You may or may not use all the parts depending on the options you choose to build. Please refer to the reference drawings in Appendix A for part locations.

Here is an overview of each part and how many of each you’ll need.

Part #	Qty	Drawing Name	Description
1	12	Right cockpit side – narrow, left cockpit side - narrow	<p>Standard Rib. You’ll make 6 of these for each cockpit side. Note that the plan shows the #1 parts with holes in them. The holes that follow the outside perimeter shape of the rib are used to attach the end caps to the cockpit. If you use the recommended ¼-20 t-nuts, you should drill these holes at 5/16”, not the ¼” specified in the drawing. The outside barrel diameter of the t-nut is just a bit smaller than 5/16”.</p> <p>These holes are only to be drilled in the parts used at either end of the left and right sides. There’s no need to drill them in the other parts.</p> <p>If you’re not building the windscreen and canopy, you’ll need to drill out the three holes that follow the inner perimeter of the rib. These are mount points for the instrument panel. They do not need to be over-drilled as the barrel on the #10 t-nut will fit the specified ¼” diameter holes. Only the ribs in position #3 need to have these holes.</p>
2	10	Right cockpit side – narrow, left cockpit side - narrow	Cockpit Section Rib. You’ll need to make 5 of these for each side. These ribs support the cockpit rails.
3	2	Forward Turtle Deck	Forward turtle deck rib. The forward turtle deck is only constructed if you’re not building the windscreen option.
4	2	Forward Turtle Deck, Instrument Panel Support	Forward turtle deck rib, narrowed. This rib has holes in it to allow long instrument panel bolts to pass through it if needed. This part is also used in the Instrument Panel Support assembly.
4A	1	Instrument Panel Support	This is a “dress” rib. It acts as a “glare shield” support of sorts. Again, only built if you’re not building the windscreen option.

The Do it Yourself Cockpit Project – Series One

Part #	Qty	Drawing	Description
5	2	Aft Cockpit Arch, Squared & Rounded	Longeron for aft cockpit arch. This part is the same regardless of which version of the arch is built (Squared or Rounded). This part may be over-drilled to 5/16" in order to accept a 1/4-20 t-nut if you want the mounting bolt to enter the part from underneath.
6	2	Right cockpit side – narrow, left cockpit side - narrow	Aft section longeron. This is the base part that Part #5 mates to. If you'd like to have the retaining bolts enter from #5, you can over-drill these to 5/16" in order to take a 1/4-20 t-nut.
7	2	Lower End Cap - Narrow	End Cap Doubler. This part is required on the aft fuselage cap – it helps structurally bind the lower cap to the Aft Cockpit Arch end cap. The forward end cap doubler is not used if you're building the windscreen version OR you want to hinge the forward turtle deck assembly for easier interior access.
8	2	Forward Turtle Deck	Forward turtle deck base longeron. If you're going to bolt down the forward turtle deck to the forward fuselage, you only need to use one mounting hole at each end. More are provided if you feel you need them. If you're going to use 1/4"-20 t-nuts, the holes will need to be drilled to 5/16". The configuration of this assembly requires that you insert the t-nuts into this part as bolt head access from this side is nearly impossible after the skin has been applied.
9	2	Instrument Panel Support	Instrument Panel Support Longeron The mounting holes in this part should be drilled to 5/16" if you're going to use 1/4"-20 t-nuts to mount the assembly to the cockpit.
10	2	Right cockpit side – narrow, left cockpit side - narrow	Forward Section Longeron. This part is present in all versions of the cockpit. More mounting holes than necessary are provided. Please use the matching holes you'd chosen for use with Part #8.
11	4	Aft Cockpit Arch, Rounded	Aft Cockpit Arch, Rounded. This component is shown on the drawing as a "half" part, and in the parts illustration as a single unit. The half parts are joined during construction and 4 of these halves are required. This part is not used with the canopy feature as the rounding is not present in the canopy frame. The holes in these parts need to be drilled to 5/16" in order to accept t-nuts.

The Do it Yourself Cockpit Project – Series One

Part #	Qty	Drawing	Description
12	2	Right cockpit side – narrow, left cockpit side – narrow	Cockpit Side Base – Narrow. This is the component that each cockpit side is built upon.
13	1	Aft End Cap – Rounded - Narrow	Aft Cockpit Arch End Cap – Rounded. This part attaches to the rounded version of the aft cockpit arch assembly.
14	1		Aft Cockpit Arch Face Cap – Rounded. This part attaches to the front face of the rounded version of the cockpit arch assembly.
15	2	Windscreen	Instrument Panel Support Arch – Windscreen Only Of the two identical parts used, ¼” holes are only required in the “front” part as shown in the illustration. #10-24 t-nuts are installed in those holes.
16	1		Aft Cockpit Arch Face Cap – Squared. This part attaches to the front face of the squared version of the cockpit arch assembly.
17	1	Aft End Cap – Squared – Narrow	Aft Cockpit Arch End Cap – Squared. This part attaches to the back face of the squared version of the cockpit arch assembly as well as to the end cap mating plate that is in turn attached to the lower end cap.
18	2	Aft End Cap – Squared/Narrow	Lower End Cap – Narrow. These two parts form the fore and aft fuselage end caps.
19	2	Aft End Cap – Squared/Narrow	Lower End Cap Door. These are the access doors that should be installed in both the fore and aft end caps.
20	2	Windscreen	Left & Right windscreen side frames
21	1	Windscreen	Lower Face Frame This component makes up the forward area of the windscreen assembly.
22	1	Windscreen	Windscreen Top Frame
23	1		Standard Arch Instrument Panel
24	6	Windscreen	Windscreen Face Frame This component is shown on the drawing as a “half” part, and in the parts illustration as a single unit. The half parts are joined during construction and 6 of these halves are required. (2 for the windscreen, 4 for the canopy framing)

The Do it Yourself Cockpit Project – Series One

Part #	Qty	Drawing	Description
25	4	Aft Cockpit Arch – Squared	This component is shown on the drawing as a “half” part, and in the parts illustration as a single unit. The half parts are joined during construction and 4 of these halves are required. The holes in these parts need to be drilled to 5/16” in order to accept t-nuts.
26	1		High Arch Instrument Panel Used when installing the alternate instrument panel support arches (Part #31)
27	1		Standard Instrument Panel. This design is used when the windscreen/canopy option is not used.
28	4	Monitor Deck	Monitor Deck Longerons Only used with Windscreen option.
29	4	Monitor Deck	Monitor Deck Ribs
30	1	Monitor Deck	Monitor Deck Face
31	2		Alternate Instrument Panel Support Arches These are only used with the windscreen option and are the mating part to Part #26.
32	1		Forward turtle deck end cap. This part attaches to the Forward Turtle Deck Assembly.
33	1		Cockpit Center Section.
34	2	Right cockpit side – narrow, left cockpit side – narrow	Cockpit railing. This is an alternate part design for those that can cut angles in flat stock. Using this part will eliminate the requirement to build up the outer surface of the cockpit rail in order to support the fuselage skin.

Chapter Five - Constructing the Center Base

The first part to be built is the “center core”. All the sub-assemblies for the cockpit depend on this part being accurate, so please take your time!

For this assembly, you’re going to need the following materials:

Qty	Description
4	72” 2x4 – Used for left & right cockpit sides and the center core sides
1	72x24 ½” Cockpit Floor (7/16” OSB or ½” MDF)
2	21” 2x4 – Fore & Aft ends
42	#8 1-1/4” wood screws
22	#8 2-1/2” wood screws
16	1/4”-20 1” hex head bolts
16	¼” washers
16	¼-20 t-nuts
4	3” Caster wheels
1	¼” drill bit
1	5/16” drill bit
1	7/64” drill bit (used for pilot holes for #8 screws)
1	Micro-stop (or other countersink bit)

The reason you need all four of the 72” 2x4s now is that you’ll have to create left & right alignment marks and get the side section mounting holes drilled.

The first thing to do is take your four 72” 2x4s and clamp them together at the ends and then mark them like this:

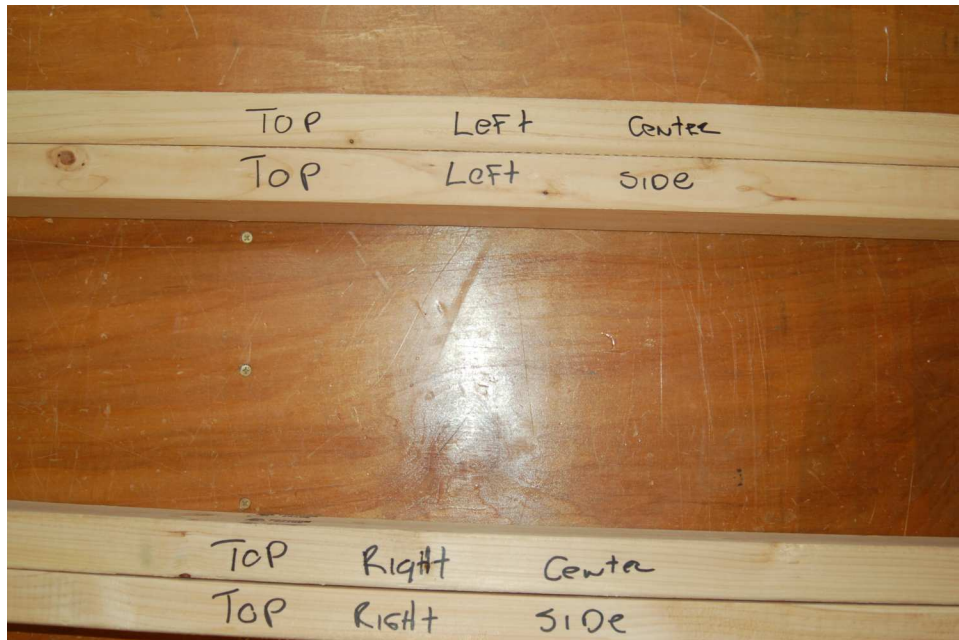

The Do it Yourself Cockpit Project – Series One

This is done in order to make sure that when you drill the mounting holes for the side sections (the next step), the left and right side mounting holes will align perfectly. By drilling both parts at the same time you don't have to worry about getting two identical hole layouts done on each part.

Leaving the parts clamped together, make a mark on the wide face of the top 2x4 at 36". Then measure 14-1/2" from that point and make another mark. Move another 14-1/2" down and make another mark. Do the same on the "other" side of the first 36" mark. You should have five equally spaced marks along the length of the 2x4 now.

Then take your combination square and set it up so that only 1-3/4" is sticking past the flat edge of the square, like this:



The Do it Yourself Cockpit Project – Series One

You're then going to drag a pencil and the combination square along the top of the 2x4 in order to make a centerline along the whole board, like this:

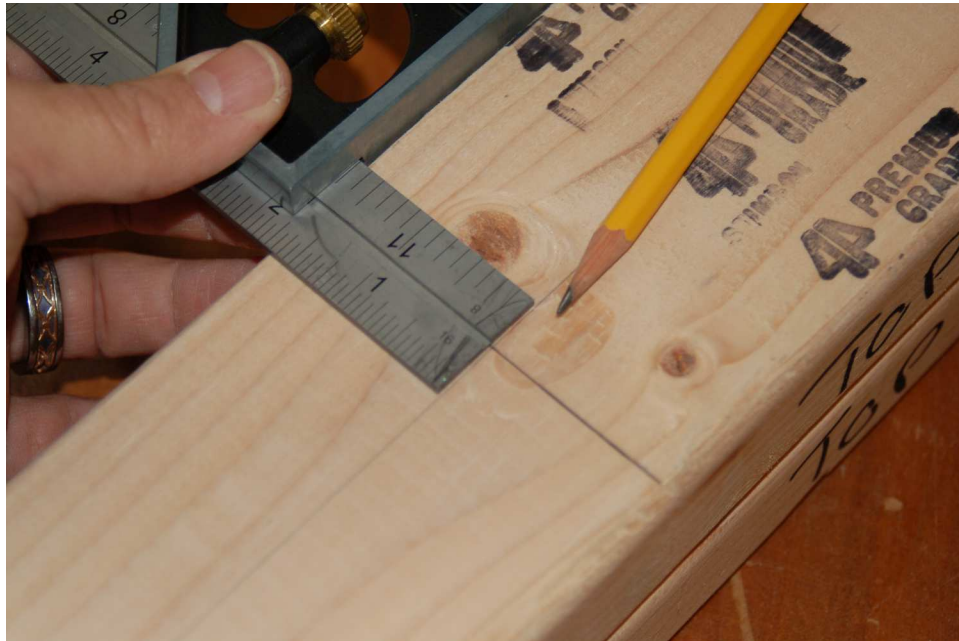

Do this on both your paired 2x4s and then drill a $\frac{1}{4}$ " hole through both of the clamped 2x4s at the marked locations. After you've done this, change to a $\frac{5}{16}$ " drill bit and drill out the $\frac{1}{4}$ " holes that are in the parts marked "left side" and "right side". You'll install $\frac{1}{4}$ "-20 t-nuts into these holes later.

Now it's time to create the base frame for the cockpit center section. The base frame consists of two 72" 2x4s and 2 21" 2x4s. These parts are attached with the 8 2-1/2" wood screws listed above. Note that these screws are not meant to be structural. They're only there to hold the frame together until the cockpit floor is installed.

The Do it Yourself Cockpit Project – Series One

Clamp the ends of the framing together like this:

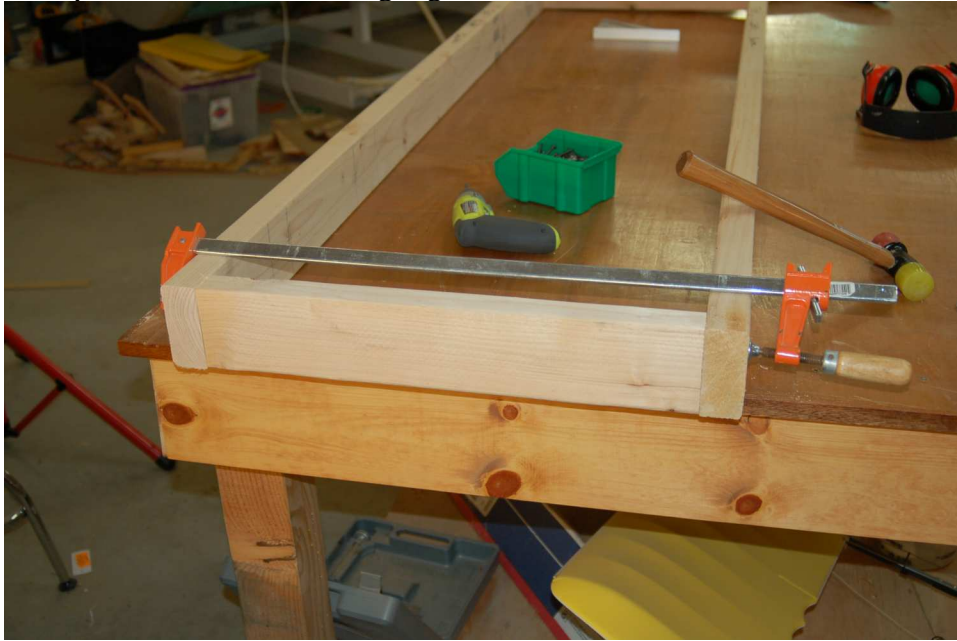

After clamping both ends together as shown above, verify that the corners are as square as you can make them – this is very important. Also, grab a tape measure and check to make sure that the width of the frame as measured from the outside surface of the 2x4s is 24". If it's not, you need to make sure that you've cut the shorter 2x4 part to exactly 21".

Now that you're all squared up, place two screws at each corner like this:



The Do it Yourself Cockpit Project – Series One

Before you mount the cockpit floor to the base frame, you should mark the sides of your 2x4s with the same markings you put on the top in the first step. What I'm talking about looks like this:



This is done to help you identify which side you're working on after the cockpit floor is installed. 😊

Now I want you to set your combination square to $\frac{3}{4}$ " and draw a line around the entire perimeter of the 72x24 cockpit floor section. If you start at the far end and walk backwards, it's a huge help. Just hold the pencil tip to the center of the ruler in the combination square and slide the pencil and the square along at the same time.

The Do it Yourself Cockpit Project – Series One

You should end up with lines that look like these:



Now measuring from where the lines intersect at the corner, I want to you to put a mark every 4-1/2". These are your screw location marks. It's not perfect as the screw location from the last mark you make on the long edge to a corner won't be 4-1/2" from the corner line intersection, but that's ok. Do the same along the short edges. The short span will only have four marks on it.

Now apply a bead of glue on the top of the base frame and set the cockpit floor on it. Drill 7/64" pilot holes in to corners along the long edge. You now need to make sure that the frame is square to the floor. A big help to getting the frame squared to the floor is to use clamps to "pull" it square. If you don't have a single clamp that can span 72" easily, you can "daisy-chain" clamps together to reach where you need to. This is what I had to do. ☺ (Thanks to Rob for this money saving idea.)

The Do it Yourself Cockpit Project – Series One

Here is a picture that shows what I mean:



It looks like of silly, but in a pinch it'll get the job done. As you bring the frame square, drill a pilot hole in the corner, countersink it and throw a screw into it. This will help hold it. When you're sure you're all squared up, drill, countersink and install the screws along the short edge.

You now need to correct for any bow-out that the long 2x4s may have. In order to do this, you'll need a couple of 24" clamps set up like this:



The Do it Yourself Cockpit Project – Series One

If your 2x4s have a bow-in problem, you can correct it by sliding in some 21” lengths of 2x4 to the underside until you’ve got the long edges screwed down. Once you’re satisfied with whatever correction was needed, go ahead and drill all the pilot holes, countersink ‘em and drive in your screws. When you’re done, you should have something that looks like this:



Ok, now it’s time to add the four casters to the base so you can move it around when it’s done!

In order to mount the casters, we need to cut a support plate that they’ll bolt to and that plate will in turn be attached to the bottom of the cockpit center frame.

Cut two 5” wide by 23-7/8” long strips of 3/4” AC ply wood (the scrap mentioned at item #15 in the Bill of Materials list in Chapter Three). Set up your combination square for 1-3/4” and draw a line along the long edge of the wheel mounting plate as shown in the picture on the next page.

The Do it Yourself Cockpit Project – Series One

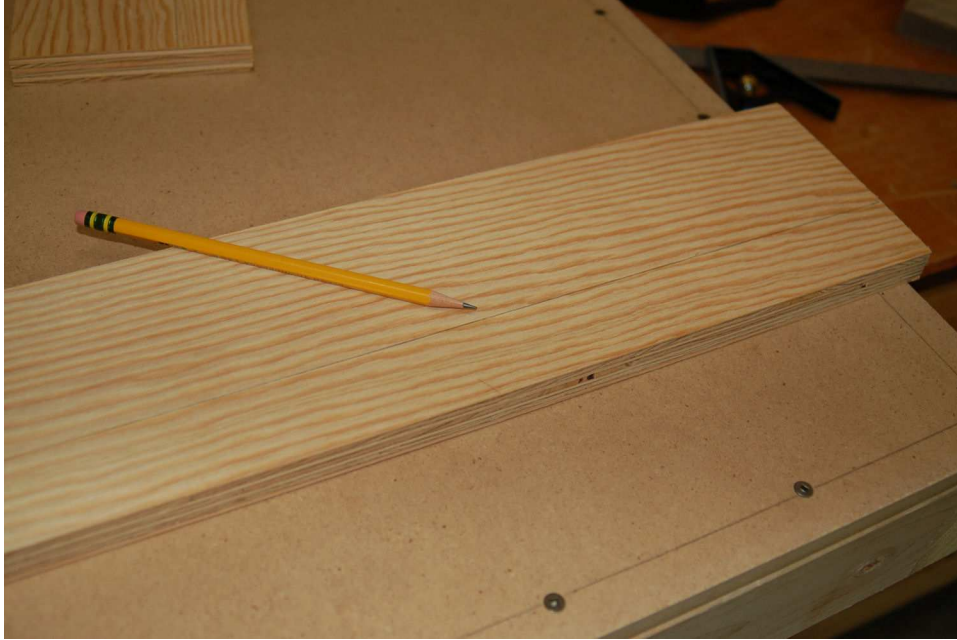

This line shows you where the “front” edge of the 2x4 will be when the plate is mounted to the cockpit floor. When you install your casters on this plate, you’ll want the long edge of the caster base to be even with this line, as shown below:



The short edge of the castor should be placed about 2” from the outside edge of the mounting plate. Mark and drill your hole centers with a smaller bit (1/4” will work fine) – you’re now going to over-drill them to 5/16” in order to install the 1/4-20 T-nuts on the underside of the mounting plate.

The Do it Yourself Cockpit Project – Series One

The simplest way to set the t-nuts into the wood is to do it at the same time you install the casters. Just hold the t-nut in the mounting hole and thread in the 1" 1/4-20 hex head bolt (and washer!) through the first mounting hole in the caster base plate. Repeat with the rest and as you tighten the bolts, the prongs will be drawn into the wood. You want the t-nut to be tightly flush against the wood; cutting into it a bit is ok too.



After you've got all four casters mounted on the two base plates, you need to mount those plates on to the bottom of the cockpit center section. Set your combination square for 3/4" and draw center lines along the short edges of the mounting plate and along the long edge that will be over the 2x4. Mark the side hole centers 3/4" from the edge of the board. Mark the 12" point along the long edge and to 6" on either side of that mark. Drill pilot holes and countersink. Each end takes 7 2-1/2" wood screws as shown below:

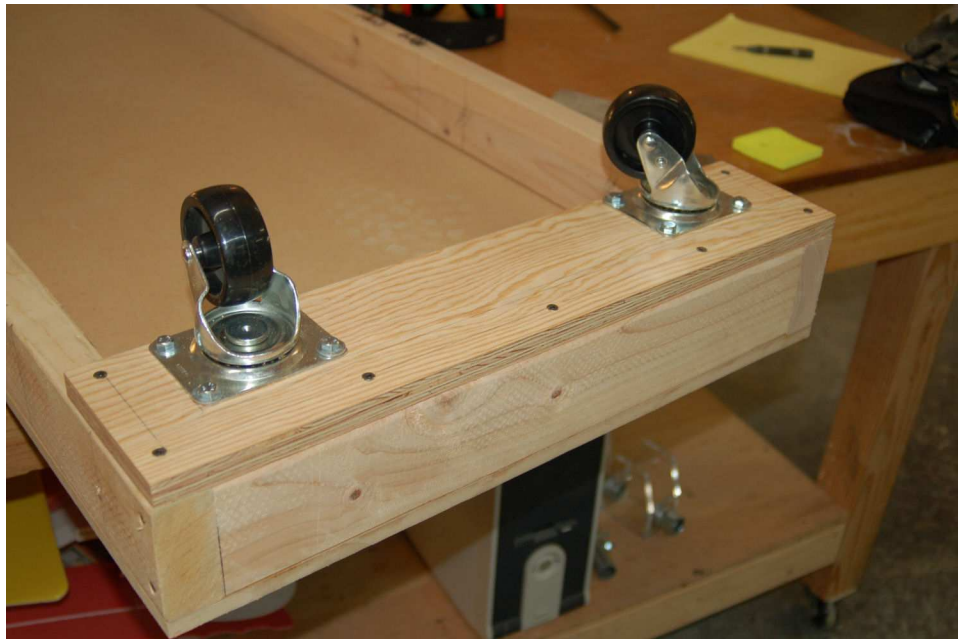

The Do it Yourself Cockpit Project – Series One

Next, you should over-drill the side holes to 5/16" and get the 10 t-nuts installed:



You now have a complete center section for your cockpit or the largest skateboard guaranteed to do you grievous bodily injury the first time you take it outside. ☺

Chapter Six - Constructing the Sides

Now it's time to build the two side sections. They are built opposite of each other, so please take care to not make two left or two right sides!

For this assembly, you're going to need the following materials:

Qty	Description
2	72" 2x4 – Used for left & right cockpit side support frames
2	Part #12 – Cockpit side base plates
4	5" 2x4 – Used for the left & right cockpit side support frames
44	#8 1-1/4" wood screws
8	#8 2-1/2" wood screws
4	Part #1, standard rib with end cap mounting holes
6	Part #1, standard rib with no holes
10	Part #2, cockpit section ribs
2	Part #1, standard rib with instrument panel mounting holes
1	Part #34 – cockpit rail (left)
1	Part #34 – cockpit rail (right)
2	Part #10 – forward section longeron
2	Part #6 – aft section longeron
10	72" 1" x 1/2" stringers
1	7/64" drill bit (used for pilot holes for #8 screws)
1	Micro-stop (or other countersink bit)
1	Two face rubber mallet (one with rubber on one side and plastic on the other).

The first thing I need to talk about before we begin is the cockpit rails. The cockpit rails are made from 3/4" stock – you can use pine, MDF, plywood or whatever you've got handy that's 3/4" thick. The prototype used 3/4" pine and the one I'm building along with you uses the new rail design in MDF.

The old style rail in the prototype wasn't notched – the notches in the updated rails serve to both align the cockpit section rails and to avoid the extra filler material between the ribs that was required during the skinning phase of the prototype. The new design requires that you have a table saw and a good angle gauge.

If you don't have a table saw, you can still make the new rail design, but you'll need to narrow it down by 5/16" on the side with the notches on it. This will allow the rail to continue to act as a rib spacer and will also reduce the amount of "filler" you'll need to use before skinning the sides.

For the table saw users out there, you need to cut two angles in each cockpit rail – keep in mind that there IS a left and a right! If you're not careful you can easily end up with two parts for the same side.

The Do it Yourself Cockpit Project – Series One

The first angle you're going to cut is 33 degrees. Set up your table saw so your angle gauge (you DID get a digital angle gauge, didn't you? ☺) looks like this:



This little gadget makes life SO much easier. If you don't have one, stop right now and go get one. It's a Wixey Digital Angle Gauge. Anyway....

Now that you've got the saw blade set at the right angle, you need to to lower it until the highest point on the blade is $\frac{3}{4}$ " from the table surface:

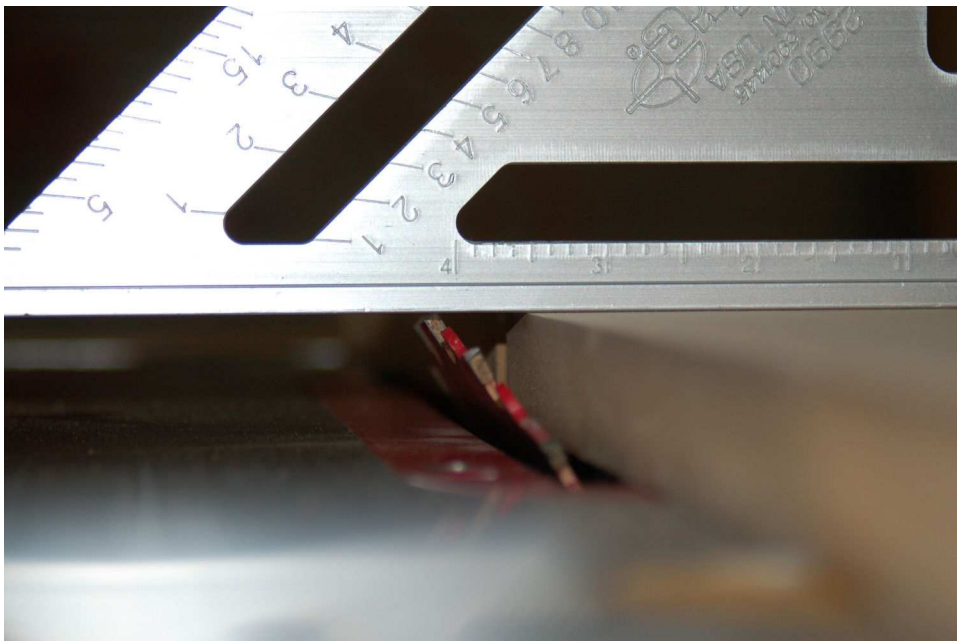

The Do it Yourself Cockpit Project – Series One

This is done because the next step is to position the table saw fence exactly 2-15/16” from the highest point on the saw blade:



Once your fence is set, you can move the blade up just a little bit. For those that haven't done this before, in order to get the correct distance from the fence to the inside surface of the blade, you've got to get the blade set at the same height as the material you're cutting, otherwise the pitched angle of the blade will cause your distance measurement to be incorrect.

When you cut the left rail, position it into the saw with the two notches that are close together are the “start” point, like this:



The Do it Yourself Cockpit Project – Series One

The right side rail should be positioned so that the two notches are opposite of how you positioned it for the left side cut:

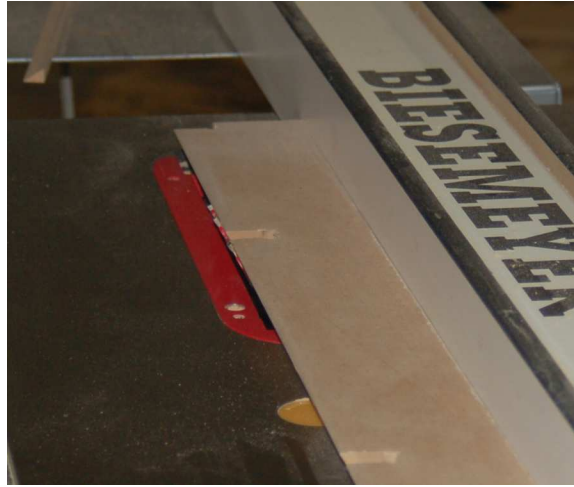

When you're done, you should have a pair that looks just like this:

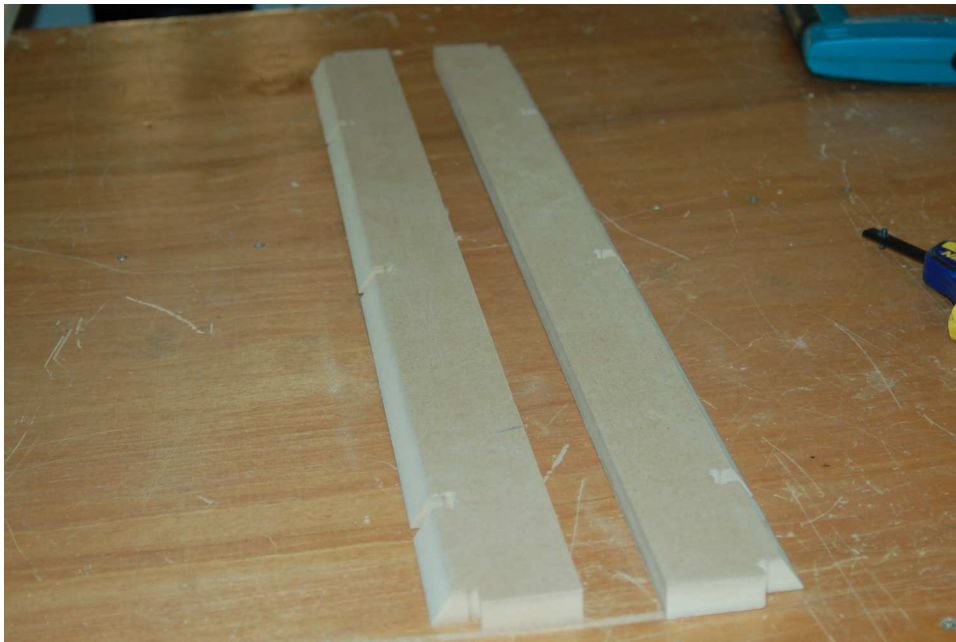

Now you need to trim the rail down by about 1/8" or so. Set your table saw for 2-13/16". You're going to trim the "pointy" ends off of the rails in order to make the next (last, I promise!) bevel cut on the rail to finish its shape.

The Do it Yourself Cockpit Project – Series One

When you're done with the cut, it should look like this:

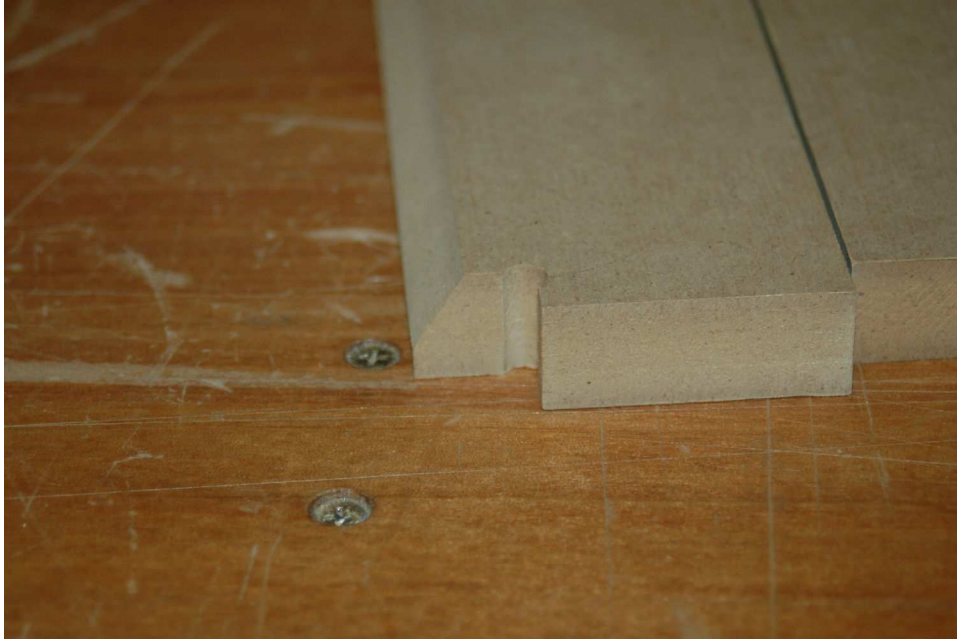

The next bevel cut is kind of tricky, so please take your time and be VERY, VERY careful! Table saws live and die by how much human blood they consume over their service life. You don't want to give them too much at one time. They'll be hungry for more and may start to stalk you. ☺

You need make a spacing template made from card stock that follows the outline of the cockpit rail rib, like this:

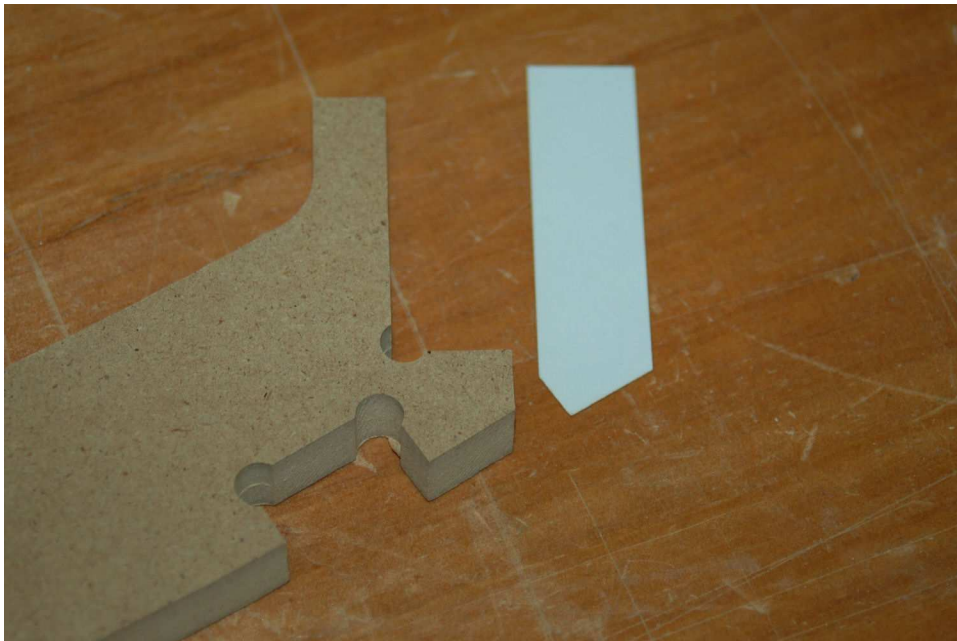

The Do it Yourself Cockpit Project – Series One

Set your table saw for a 32 degree cut and use the card template you just made to set the fence distance from the face of the blade:

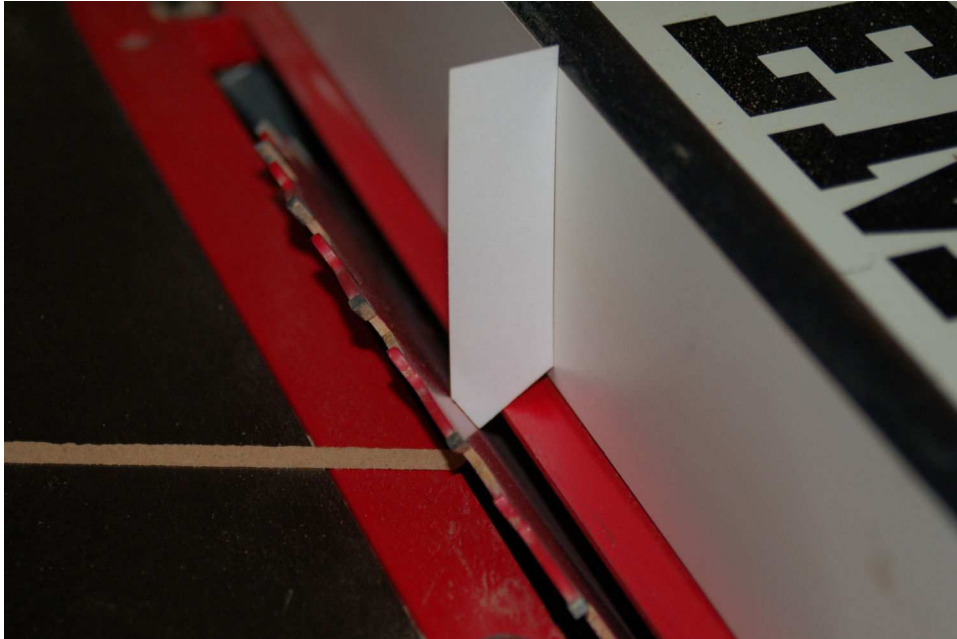

Now carefully run the cockpit rail through the saw with the rail oriented just like you see in the template above – with the already beveled edge “facing” the fence. When you’re done, you should end up with this:

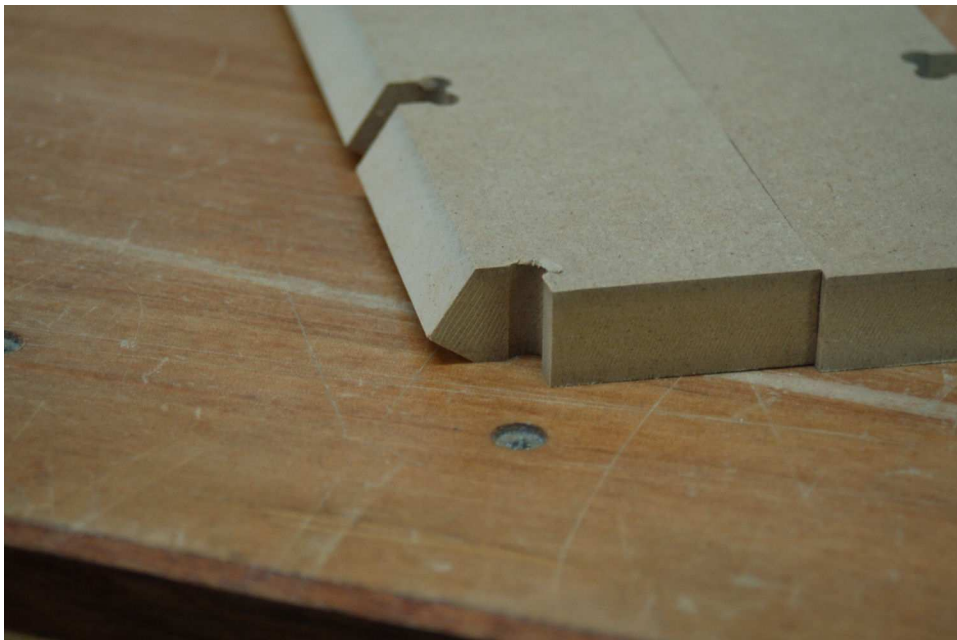

These two cuts ensure that the cockpit rail fits the cockpit rail ribs perfectly, without interfering with the first stringer that is placed in the notch right below the rail.

The Do it Yourself Cockpit Project – Series One

Remember those notes I had you write on the 2x4 parts about which was left, etc? Here's where that pays off:



This is how you want to align the first part of the side sub-frame. By lining it up on the floor like this, it tells you which is the inside face and which is the outside. This is important.

Measure 1" from the end and make a line on the outside face of both the 72" 2x4s on both ends. This is the alignment mark for the 2 5" 2x4s that make up the rest of the sub-frame assembly. When you've got the marks made, place the 2x4 against the outside face of the 72" board and screw it into place. When you're done with both sides, each should look like this:



The Do it Yourself Cockpit Project – Series One

Now you need to set up your combination square for $\frac{3}{4}$ " and run lines down the long end of both cockpit floor parts as well as centered along where the 5" 2x4 runs. This is about 1-7/8". The end result should look like this:

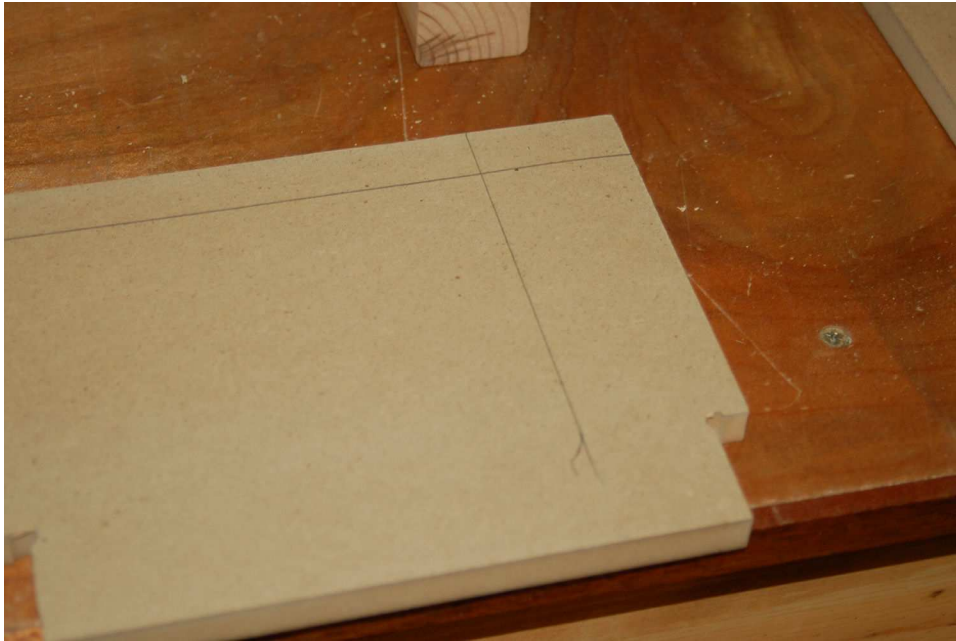

Note that the cockpit floor parts have a left and a right side. Don't do what I did and make lines on the same side of both parts. I had to flip one over and do it again. Starting at the corner where the two lines intersect, make marks every 4 inches along the long side of the floor. These are where you're going to put in the 1-1/2" wood screws. For the screws that will go into the 5" part, measure back $\frac{3}{4}$ " from the outside edge of the part, mark that point and again at 3".

The Do it Yourself Cockpit Project – Series One

In order to help orient yourself with how the sides fit, just remember that the cockpit side floors have a big notch towards the aft end of each. Also remember that the notches face outward, “pointing” the same direction that the 5” 2x4 ends do. In order to keep it straight for myself, before I moved to the next step, I set the sides up like they would be if they were installed:

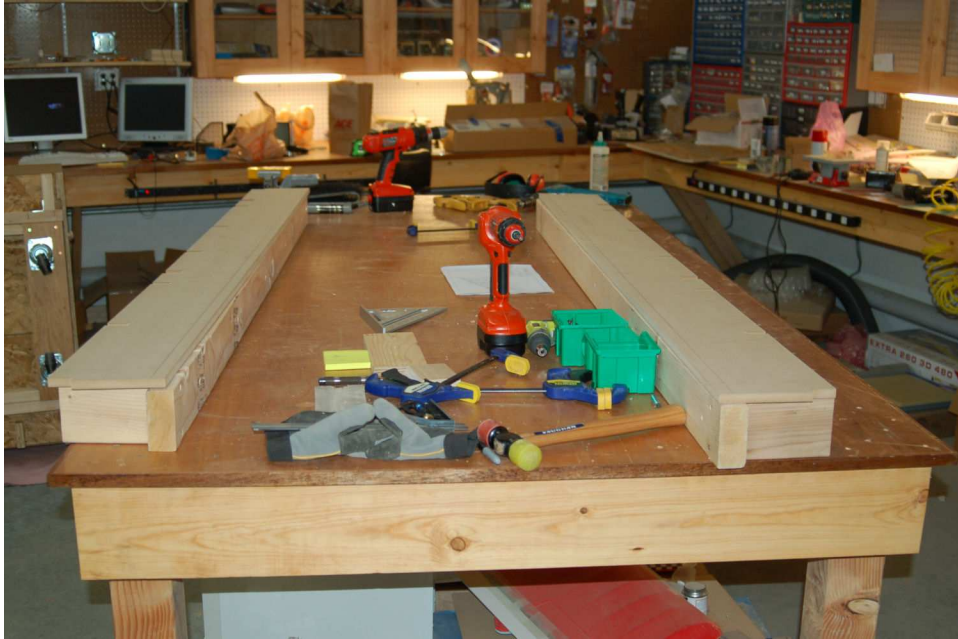

The Do it Yourself Cockpit Project – Series One

After making sure that you're not making two of the same side, run a bead of glue along the top of the 2x4s. Set the floor down on the sub-frame and get it all aligned.

Drill a pilot hole at the line intersection on the aft end. Countersink and screw this down. Re-check the alignment against the 2x4. You want the "inside" edge of the floor to be flush with the "inside" edge of the sub-frame. When you're done, it should look like this:

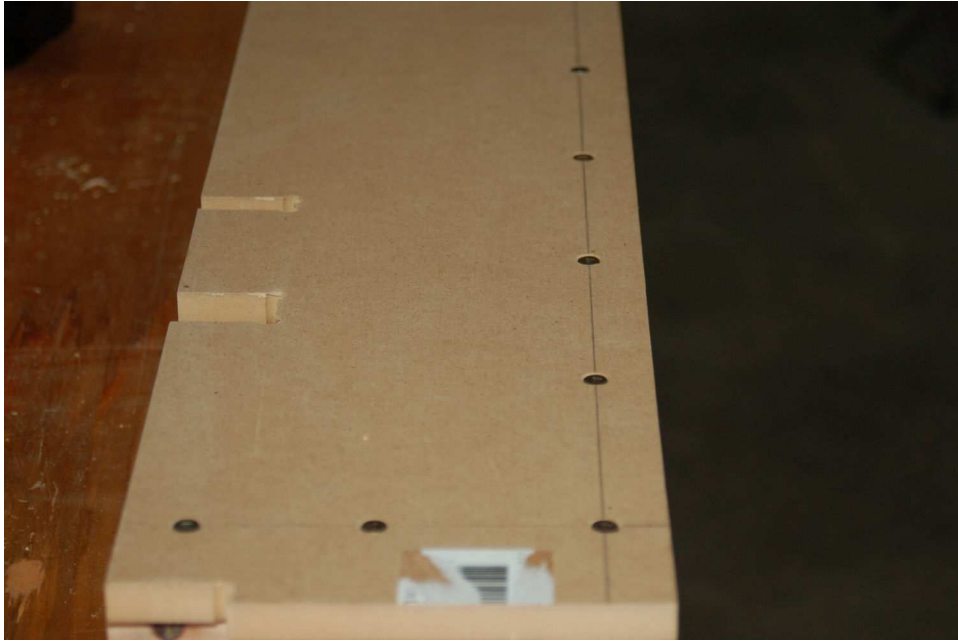

Now go ahead and build the other side using the same steps we just did for this side. When you're all done, you should have this:



The Do it Yourself Cockpit Project – Series One

Now it's time to start setting ribs on those new floor frames you just built!

You want to make sure you get a good fit on these, but not so tight you have to nearly beat them to death with a hammer to get them set in. I can guarantee you that if you hit a rib too hard, you'll break it. It's happened to me twice, once on the prototype and again when writing this documentation. The notches are all .47" wide, which will serve both OSB and MDF users, however if you're going to use MDF, you **MUST** ensure that the fit is snug, but not so tight as to prevent you from installing the rib without resorting to beating it in with the mallet. ☺

The ribs that are installed on either end have a number of holes in them to accept the t-nuts for the end cap mounting. These holes need to be 5/16" in order to accept the barrel of the t-nut.

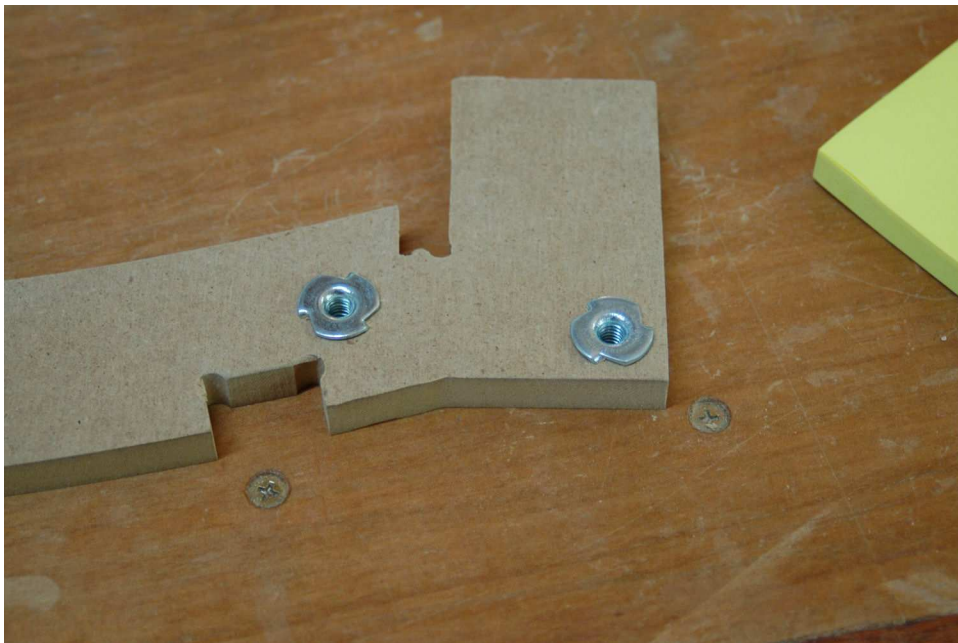

The easiest way to get these installed is to place the t-nut in the back of the rib and then insert a 1" hex head bolt with a washer on it from the other side. Tighten it fully to seat the t-nut into the material.

If you're not going to use the windscreen & canopy option, now is a very good time to install the six #10-24 T-Nuts (three each side) used to attach the lower instrument panel to the cockpit. Doing it now will save you grief about it later on.

The Do it Yourself Cockpit Project – Series One

The end ribs are installed by gluing & screwing the ribs into place. Draw a line that divides the base notch and mark center points at $5/16$ " from each edge:

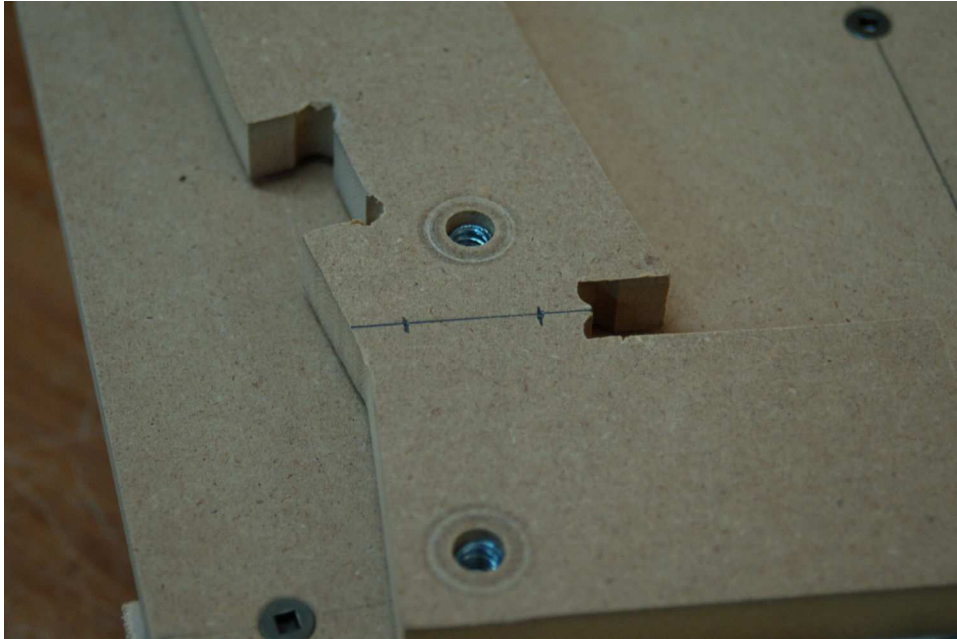

Apply glue to the mating surfaces on the rib and the cockpit floor and tap it into place. Drill two $3/32$ " pilot holes and countersink them. Install two 1" #6 flat head screws:

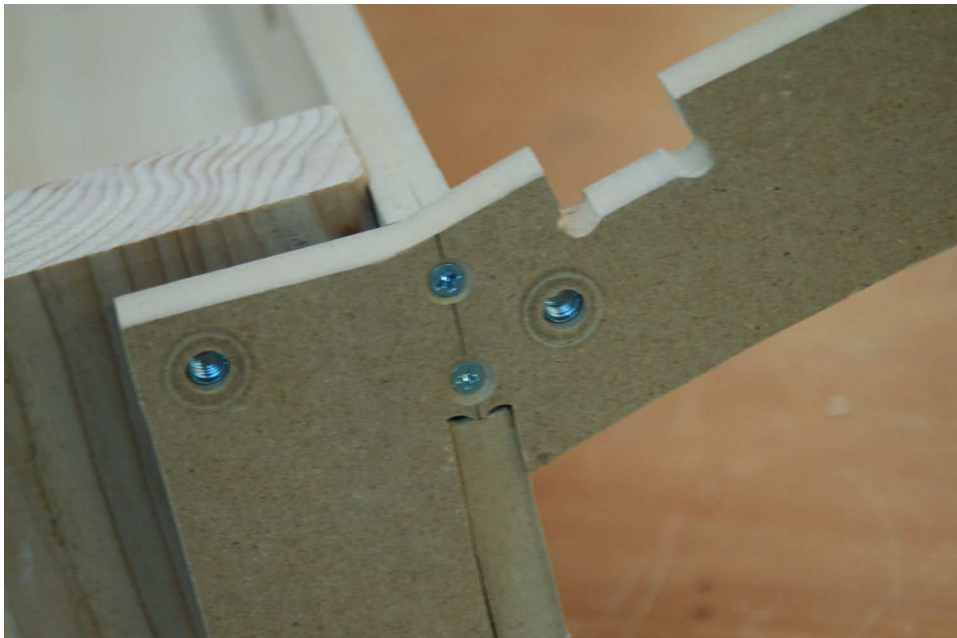

The Do it Yourself Cockpit Project – Series One

Following the appropriate drawing in Appendix A (left & right cockpit side parts arrangement), go ahead and install the remaining ribs. Repeat the steps outlined above for the other end-cap ribs.

Next, you'll need to install the fore & aft longerons as well as the cockpit rail. The aft longeron has two 5/16" holes in it to accept t-nuts:



The aft longeron is attached with glue and nailed into place with the pin nailer and 3/4" 18ga brads. If you're unable to use that method, you can also use 3/4" #6 screws, but make sure you take care installing them. MDF and OSB do not take screws very well edge-on. Pilot holes are required.

When installing the cockpit rail, make sure that the rib notches are not too tight – open them up a bit with 60 grit sandpaper if needed. You don't want to apply a lot of force when installing it or you run the risk of breaking one of the cockpit section ribs.

The Do it Yourself Cockpit Project – Series One

Apply glue to each notch and nail into place with 1” 18ga brads to each rib, or use 1” #6 screws, following the caution I mentioned above.



The Do it Yourself Cockpit Project – Series One

Next up is the fore top longeron:



Unlike the aft longeron, this part has no t-nuts installed in it. If you're building the windscreen for your cockpit, these holes are unused. If you're not going to build the windscreen, these holes are used to attach the top turtle deck assembly to the cockpit.

Now it's time to install the 1" x 1/2" x 72" stringers. The best way to make these is with a table saw and scrap sheet material left over from cutting the parts out. You'll want to cut a few test parts to get the width of the stringer just right. The stringer needs to be a tight fit into the notches in the ribs. Each rib notch needs to be glued:

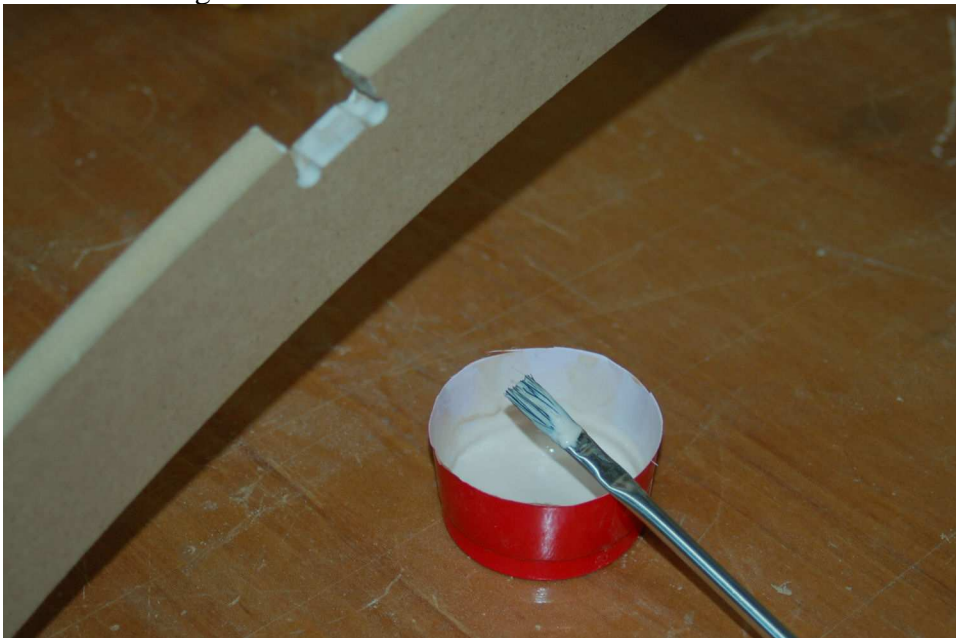

The Do it Yourself Cockpit Project – Series One

In order to seat the stringer in each rib notch, you'll need to use a clamp to press the stringer all the way into the notch:



Do NOT try to hammer the stringer into place. You'll only break the rib. By using the clamp as a press, you can get the stringer installed properly without stressing the rib structure. Repeat this process for all five stringers and you'll be done in no time!



Chapter Seven

The Forward Deck & Instrument Panel Arch

If you're going to build the windscreen & canopy, you can skip this section and move on to Chapter 8, The Aft Cockpit Arch.

For this assembly, you're going to need the following materials:

Qty	Description
2	Part #3 – Forward Deck Rib
2	Part #4 – Forward Deck Rib, instrument panel mount
1	Part #4A – Instrument panel support arch
2	Part #8 – Forward Deck Longeron
2	Part #9 – Instrument panel support arch stringers
12	1/4-20 T-Nuts

The forward deck is a pretty quick build. You'll need to take care that the middle notch on the longerons is not too tight – just like building the sides, you don't want to break them while you're installing them.

The center notch in the longerons is offset a bit, so you need to make sure you orient the parts to face “forward” when you're assembling the deck. The easiest way to do this is to identify which end is the “front” end. You can do this from measuring from the end of the longeron back 11”. The 11” mark will put you at the center of the mounting holes on the “forward” end of the center notch. Also, the “forward” end of the center notch is 11-3/4” from the forward end of the longeron. Mark the forward end of the longerons with an arrow, like this:

The Do it Yourself Cockpit Project – Series One



The Do it Yourself Cockpit Project – Series One

You want to start off by mounting the middle rib (Part #3) to each longeron at the middle notch, like so:

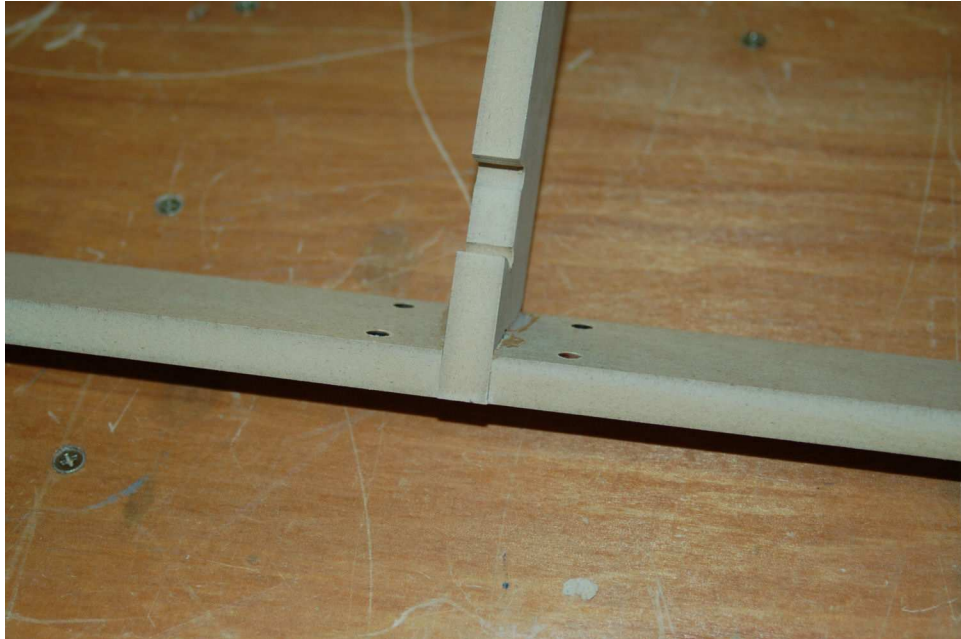

I will guarantee you without a shadow of a doubt, if you force the rib into that notch, you'll snap the longeron in half. I know I just did it myself. Make sure you sand the middle notches so the rib fits snugly, but doesn't require much force to insert. Glue the rib in place and pin it from below with one or two 18ga 3/4" brads.

The Do it Yourself Cockpit Project – Series One

Next, you'll add the second large rib to the front of the forward deck assembly:



When attaching this part, you'll need to put one 18ga pin in the end and two on the bottom, like so:



It's kind of difficult to see, but the pins went in where you see the material dimpled. Don't forget to glue this down!

The Do it Yourself Cockpit Project – Series One

Next you're going to install the instrument panel support rib – it doesn't actually support the instrument panel, but it allows longer screws to be used if needed:

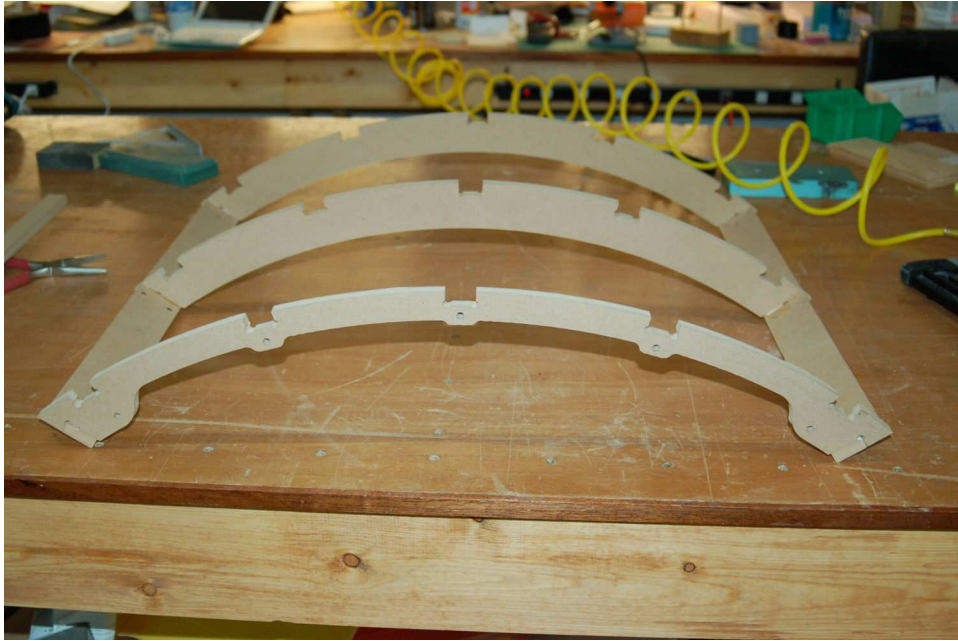

Now it's time to add the stringers. Go ahead and place the very top stringer first, like so:

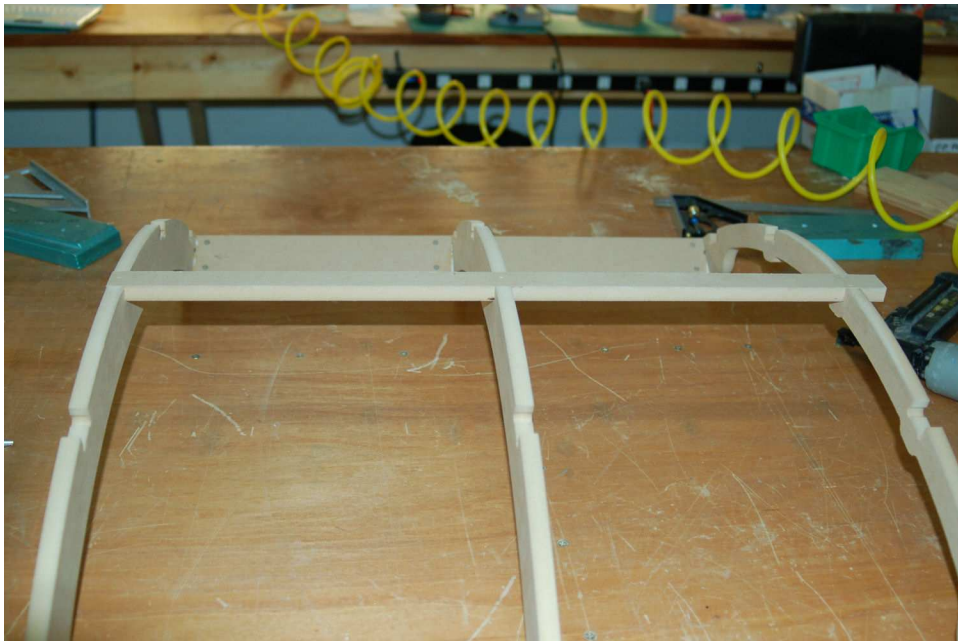

This one is done first because it will allow you to ensure that the ribs are all square to one another. To do this, measure the distance between the ribs at the base of each rib, and compare that measurement to the same one taken at the top stringer location.

The Do it Yourself Cockpit Project – Series One

Install the apply glue to the stringer notches and insert the stringer. Once you've done that, you can tap the middle stringer a bit to get it to match the bottom measurement. Once you have it square, pin it in place.

Next, put in the bottom stringers on either side:



You can go ahead and get the rest of the stringers installed. Once you've got any extra stringer length trimmed off, set this part aside for now. Make sure you've got it on a level surface where the glue can dry. You don't want this assembly warping on you.

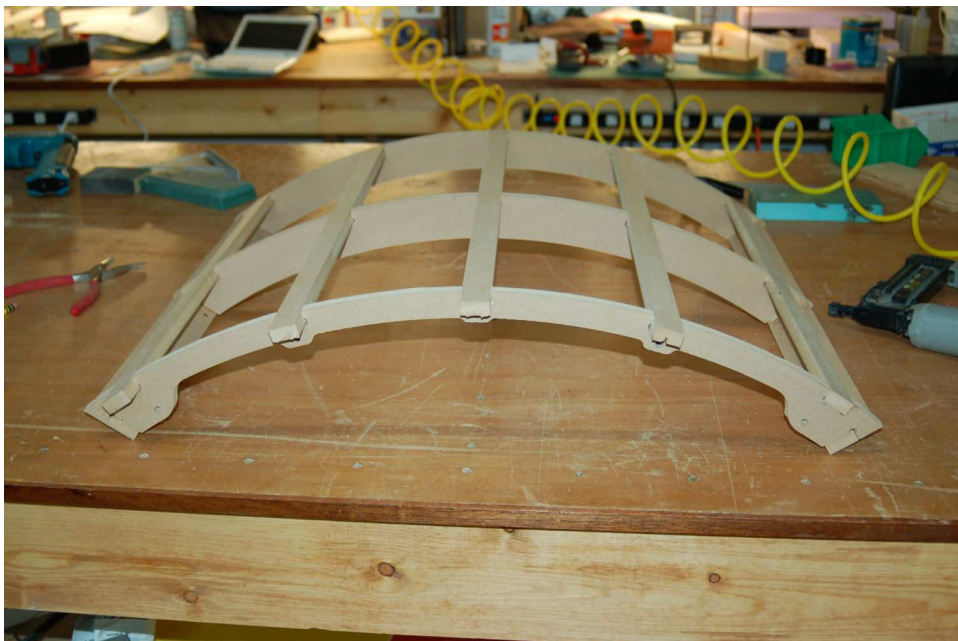

The Do it Yourself Cockpit Project – Series One

At this point you should over-drill the mounting holes (bottom two holes on each end) and install the ¼-20 t-nuts as shown below:

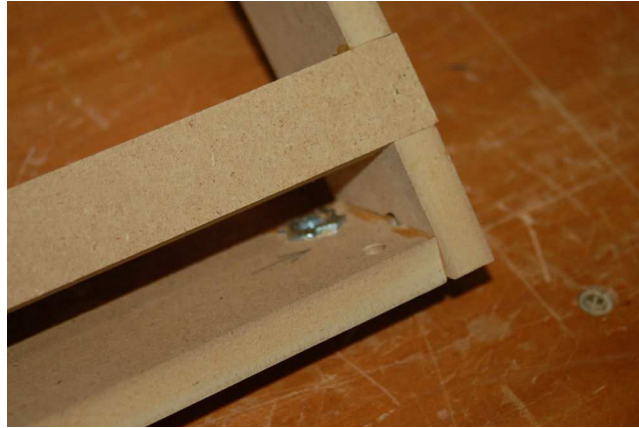

Now it's time to build the instrument panel arch. This assembly was designed in order to support your instrument panel while allowing you to remove the forward deck. By keeping it a smaller part, it can be more or less “permanently” mounted so you don't have to remove the panel in order to work on it.

Next you are going to need to install the four ¼-20 T-nuts in the forward frame:



It's very hard to see, but there is a white dot next to each one you need to have installed. There are 7 holes in the forward rib, but you're only going to install T-nuts in four of the holes. This is because the stringers block the other holes. The “blocked” holes will eventually have cut down screws for “show” installed.

The Do it Yourself Cockpit Project – Series One

We'll start out by gluing and pinning the instrument panel arch longerons and the "top" stringer, like this:

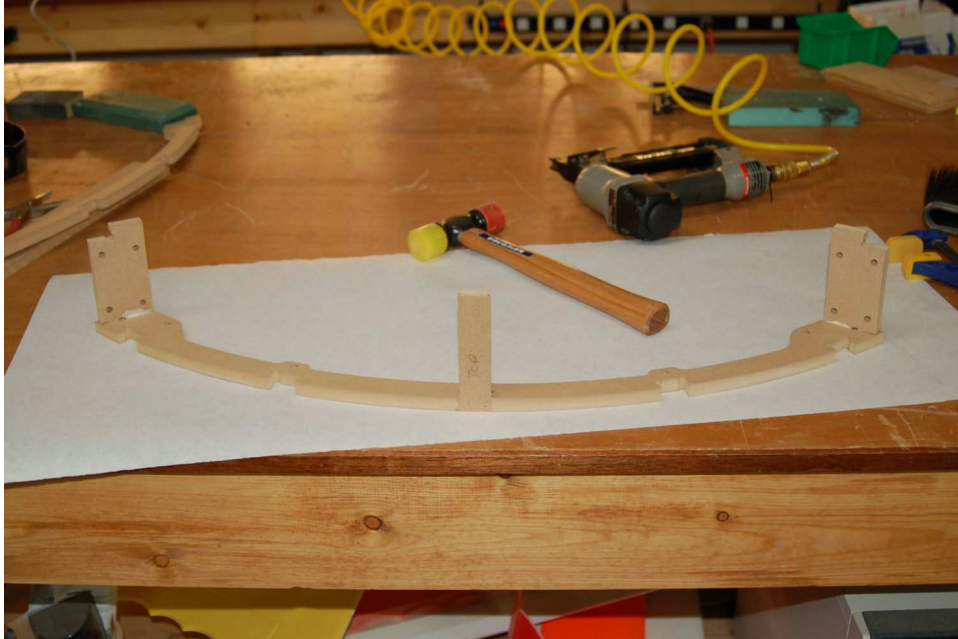

To make the stringers the correct length, it would be easier to just create 5 stringers that are the same length as the panel arch longerons. It's pretty hard to read out 4.235in on a measuring tape. 😊

The Do it Yourself Cockpit Project – Series One

The instrument panel arch is started this way because it's easier to make sure everything stays aligned long enough for you to get it assembled. Once the step above is done, attach the other instrument panel arch rib:

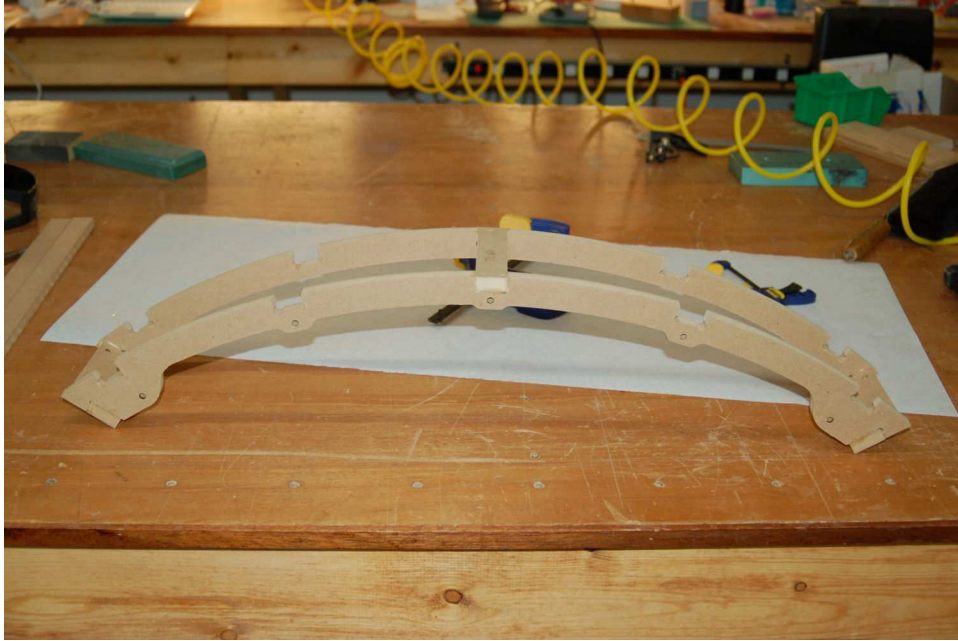

When you've got that done, install the stringers at the base on each end and then finish mounting the other two stringers.

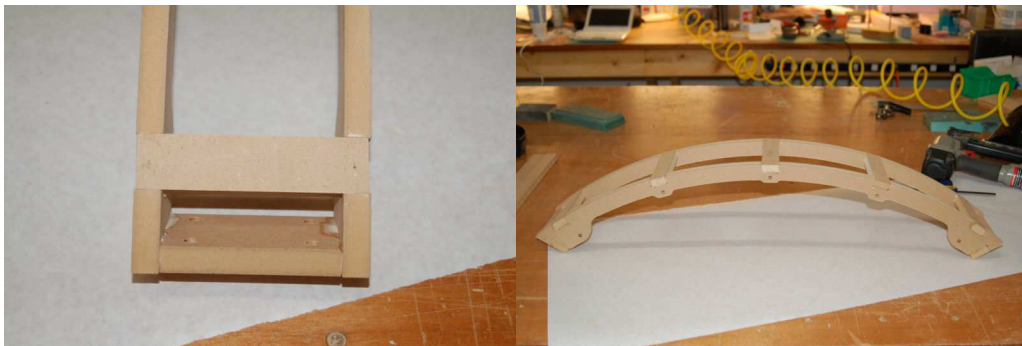

The last step is to decide how you want your instrument panel mounted. My original design calls for the instrument panel arch to be installed so that the rib with the mounting holes is closer to the front of the cockpit. This allows for an instrument panel "brow". However, you're welcome to flip the part around and mount it so that the panel is closer to you. The only reason I mention this now is that you're going to have to decide where you install the 10-24 T-Nuts.

The Do it Yourself Cockpit Project – Series One

If you're going to install the arch how I originally designed it, place the t-nuts like this:



However, if you want to install it the other way, mount the t-nuts like this:

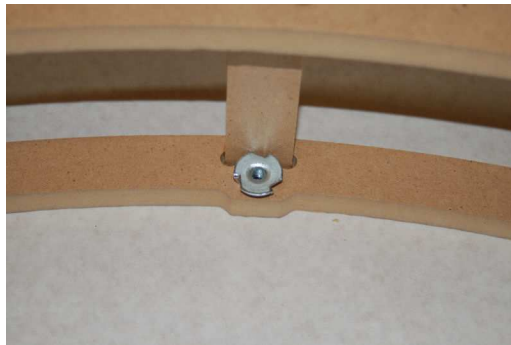

You're also going to want to drill out the base plate to 5/16" and get the 1/4-20 t-nuts installed now. Use the "lower" holes as shown in the image below:

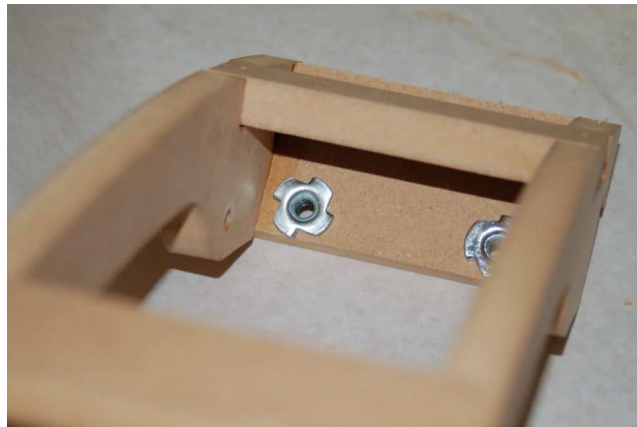

All that remains is skinning and I'll cover that later.

Chapter Eight

The Aft Cockpit Arch

For this assembly, you're going to need the following materials:

Qty	Description
2	Part #25 – Aft cockpit arch – squared (or 4 halves)
2	Part #5 – Aft cockpit arch longeron
8	1" x 1/2" 8.23" stringer
20	1/4-20 T-Nuts

If you've cut Part #25 as four halves as I show in the plans, you're going to need to glue and pin them together before we can continue:

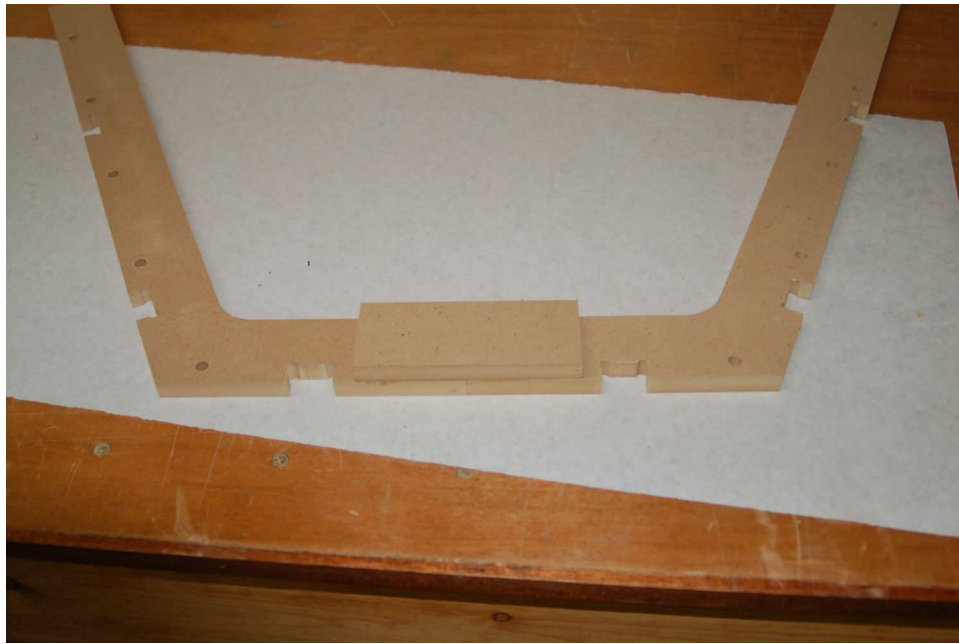

What I've done here is glue the two frame halves together and then attached a 1-7/8" x 5" x 1/2" thick doubler plate in order to help hold it together. This is one part you want to leave alone until the glue is dry.

While you're waiting for the glue to dry, go ahead and cut the 8 stringer parts you'll need to finish this assembly. You should have enough stringer scrap from the other parts to be able to do this without having to cut any new stringers. You can cut the stringers to 8-1/4". It's close enough to the 8.23" design that it won't matter much.

The Do it Yourself Cockpit Project – Series One

When the glue is dry, install the two longerons in one of the arch halves:

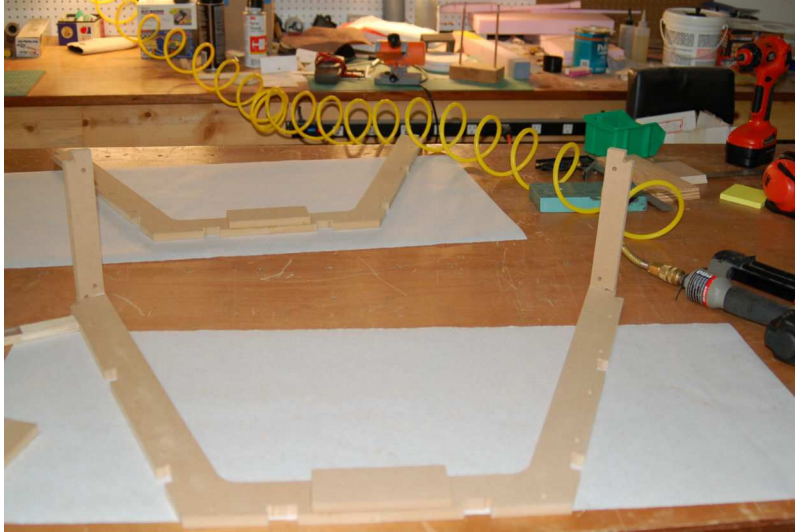

You should pin these into place as well to hold them. Next, you need to install the top two stringers and set the other half of the aft cockpit arch:



When installing the stringers, make sure you glue and pin them. Also, don't force them – sand the notches a bit if you need to.

The Do it Yourself Cockpit Project – Series One

When you're done, the assembly should look like this:



Next, install the remaining stringers:

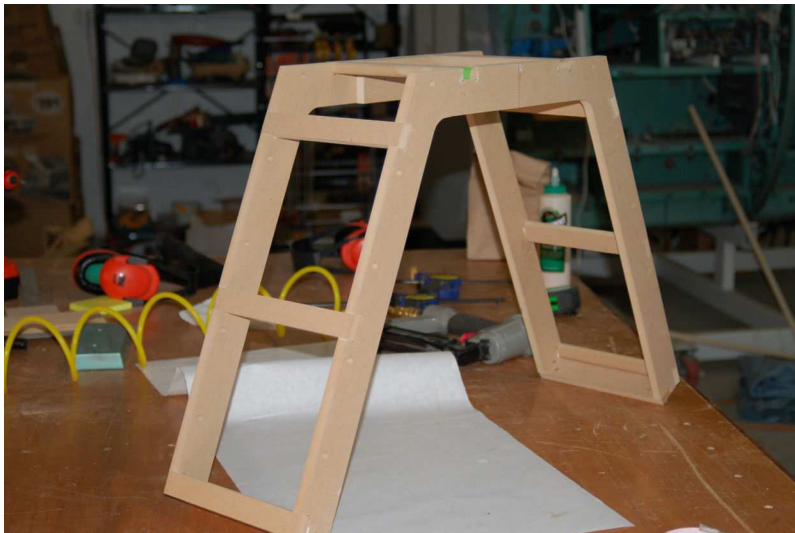

The last step is to install the 20 ¼-20 t-nuts into the frame.



Chapter Nine

Skinning the cockpit sides

For this assembly, you're going to need the following materials:

Qty	Description
2	73" x 27-5/16" 1/8" Tempered Hardboard

When skinning the cockpit, you can opt to not use the 1/8" Tempered Hardboard and use aluminum sheet instead. I won't cover how to attach it here, but the layout instructions that follow will apply.

The first thing you'll need to do after your skin material is cut is to draw a series of lines on it that will allow you to properly attach the skin to the side frames.

Measuring along the long axis of the skin material, I want you to draw a series of 9 lines:

1. 1/2"
2. 12 1/4"
3. 24 1/4"
4. 28"
5. 36 1/4"
6. 48 1/4"
7. 60 1/4"
8. 63 3/4"
9. 72"

These lines are along the "front" edge of each rib in the cockpit. All your pins will be used about a 1/4" aft of each of these lines.

Next, you need to make 6 parallel lines along the long axis – these will define the centerline of each stringer. Those measurements are:

1. 1 1/8"
2. 7 1/4"
3. 13 1/2"
4. 19 1/2"
5. 25 1/2"
6. 27"

Because the sides are mirror images of themselves, you'll need to make sure that you don't create two identical skins. The easiest way to do that is to create layouts with the horizontal line set starting on your left (the 1/2" mark is the "start") and call that the

The Do it Yourself Cockpit Project – Series One

“left” side. Create the layout on the “right” sheet just opposite that, with the ½” line starting on the “right” end of the sheet as you’re facing it. The long edge farthest away from you will be the “top” edge for both parts and that is where you measure to make your stringer center lines.

When you’re done, you should have a layout that looks something like this:

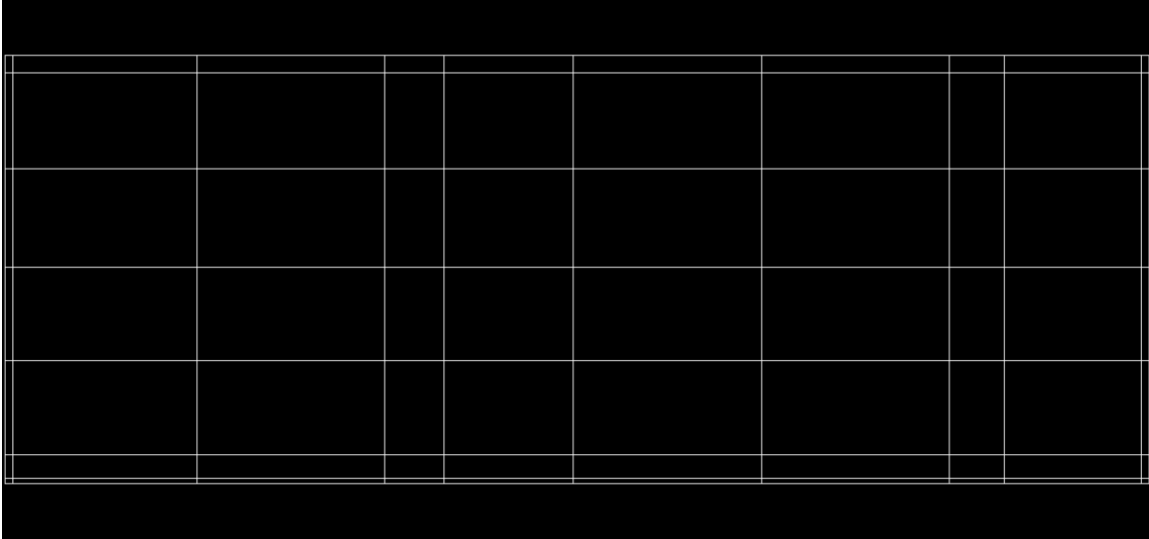

This drawing shows the general layout of the whole skin panel and is representative of what you should have on the left side. Now it’s time to attach the skin. You’ll need your pin nailer and ½” pins for this. You can also use screws if you like, but I won’t outline that process here. (Hint: get a rivet fan to help you lay out where the screws go!)

One import thing to mention – if you’re using a pin nailer to attach the skin, make sure that you’ve got the depth setting adjusted correctly. The skin material is soft and it’s very easy to drive the pin all the way through it. This is a lesson I learned building the production model shown in this manual. When correctly set, you should see a result like this:



The Do it Yourself Cockpit Project – Series One

You should be able to see the silver head of the pin and it should be flush with the surface or just a little bit below. If you have problems with setting the depth adjustment, err on the side of under-driving the pin. You can always go back over them later with a hammer and a nail set.

Take a bottle of glue and an acid brush and spread the glue in an even and thin layer all over the framing, like this:



Set the skin on the framework and align the line at the ½” mark with the leading edge of the first rib (forward) like this:



The Do it Yourself Cockpit Project – Series One

Align the top edge of the skin with the top edge of the front and rear longerons – this will result in a bit of an overlap along the cockpit rail. This isn't a problem and you'll be trimming it off later on. When you've got it aligned, clamp it and start nailing it down with the pin nailer.



I use a few extra clamps to support the framework off the table in order to make it easier to work on. Work your way back and forth, nailing the skin down as you go. If you're careful and take your time, this shouldn't be too difficult to get right the first time. ☺

After you're done applying the skin, check along the first and last ribs to make sure that the skin is firmly attached. It may lift a bit and require some clamps to keep it in place until the glue dries. This holds true for the longeron and cockpit rail areas. You can't use too many clamps. When you're done, it'll look like this:



[[[[[show trimming of skin on cockpit rail]]]]]

The Do it Yourself Cockpit Project – Series One

Chapter Ten

Skinning the Forward Deck and Instrument Panel Support Arch

For this assembly, you're going to need the following materials:

Qty	Description
1	32" x 24-1/2" 1/8" Tempered hardboard skin
1	32" x 4-5/16" 1/8" Tempered hardboard skin
40"	1/8" scrap lite ply for filler

Skinning the forward parts is pretty straightforward. The first thing you need to do is mark the nailing centerlines on your skin material.

For both the forward deck and the panel arch skin, you're going to mark a center line at 16" along the short length of the material (24-1/2"). To either side of this centerline, please draw lines at 6-3/4", 14" and 15-5/8".

Pick one edge to be the leading edge and draw a line along the 32" width at 12-9/16". This marks the middle of the rib in the center of the forward deck. The instrument panel arch component doesn't require this extra line.

Next, you need to fill in the spaces between the ribs with lite ply in order to give yourself a solid nailing surface.



The Do it Yourself Cockpit Project – Series One

Next you need to sand down the filler parts in order for it to be flush with the rib profiles.



Once this is done, set it aside for now. You need to prep the forward deck face plate. This basically means you're going to need to countersink the holes if you haven't already.



Now attach the face to the forward deck – you only need to use two screws as this is only temporary.

The Do it Yourself Cockpit Project – Series One



Now you need to mark the center line on the face and on both ends of the center stringer in order to make sure the skin stays aligned.

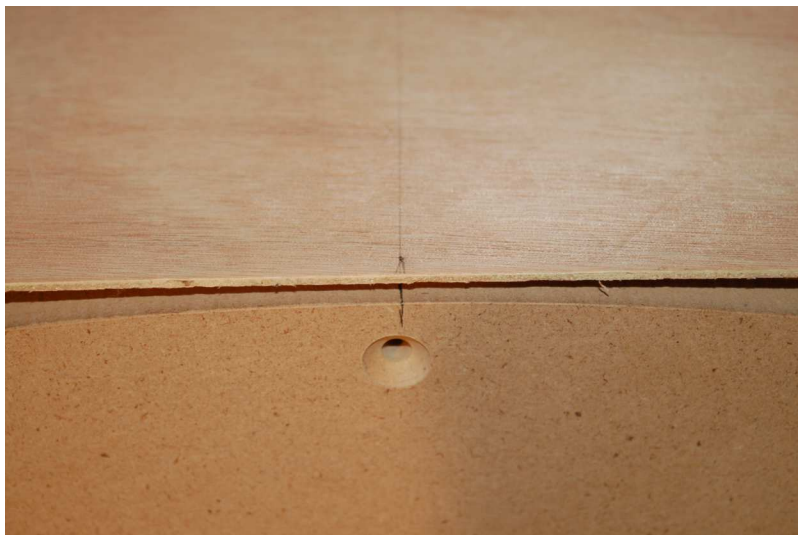

You'll note that the skin isn't MDF. For this example I switched to a 1/8" Luan door skin to illustrate an alternate skin material.

When you've got the centers marked, lay glue on all the ribs and stringers like you did for the cockpit sides and set the skin down so that the center mark along the 24-1/2" length matches the center marks you just put on the framing. Make sure that the leading edge of the skin is even with the outside face of the forward deck face plate. Clamp the skin on the back rib and then you can remove the forward plate. Clamp at the center like you did in back.

The Do it Yourself Cockpit Project – Series One



Using your pin nailer, tack down the skin along the center stringer. From there you can begin to attach the rest of the skin working your way out from that center point. It helps to have someone help you hold the skin down as you go. This is what it looks like finished:



The Do it Yourself Cockpit Project – Series One

The instrument panel arch is assembled the same way:



Chapter Eleven

Skinning the Aft Cockpit Arch

For this assembly, you're going to need the following materials:

Qty	Description
2	19-5/8" x 9-1/4" 1/8" Tempered hardboard skin
1	14-1/2" x 9-1/4" 1/8" Tempered hardboard skin

In order to skin the Aft Cockpit Arch, you're going to have to get the front and back caps finished. (Parts #16 & 17) This basically means you're going to need to drill all the countersinks:

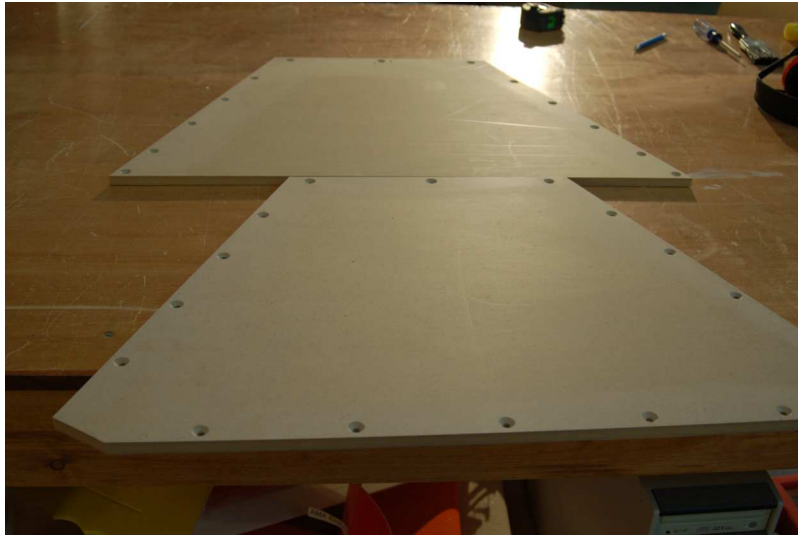

Once you've got those done, you need to attach them to the aft cockpit arch framework. You only need to use four screws per side as you'll be removing these after the skin has been attached.



The Do it Yourself Cockpit Project – Series One

Now you need to take your “side” skins and draw lines $\frac{1}{2}$ ” from the edge, along the long edge. This marks where the outside edge of your nailing area is. You can put pins *inboard* of these lines, not outboard. This is to make sure that you can remove the assembly caps later on.

Next, you’ll need to mark a line $\frac{1}{2}$ ” from the bottom edge, one at 8-13/16” and one at 17” These mark the center lines for the stringers.

Apply glue to only the arch parts itself, not the end caps. You don’t want the skins sticking to parts you’re going to remove in a few minutes.

Applying the top skin is just as easy as the sides. Draw lines $\frac{1}{2}$ ” in from the long edges, just like you did with the side skins. Then, you need to draw a line at 3-3/4” and 10-3/4”. These are the centerlines for the top stringers. Glue & nail in place like the sides. Now remove the end caps and wipe off any excess glue on them.

The end result should look like this:



Chapter Twelve

Finishing and Installing the End Caps

For this assembly, you're going to need the following materials:

Qty	Description
2	Part #18 – End Cap
2	Part #19 – End Cap Access Door
2	Part #7 – End Cap Doubler
4	2-1/2" Utility hinges with removable pins
2	Magnetic Cabinet door catches
2	Knobs
20	1/4"-20 T-Nuts (10 if you're building the Canopy & Windscreen)
44	1"-1/4" Flat head screws (34 if you're building the Canopy & Windscreen)

First up, you'll need to get the t-nuts set into both End Cap Doublers (Only one is used for the Canopy & Windscreen model).

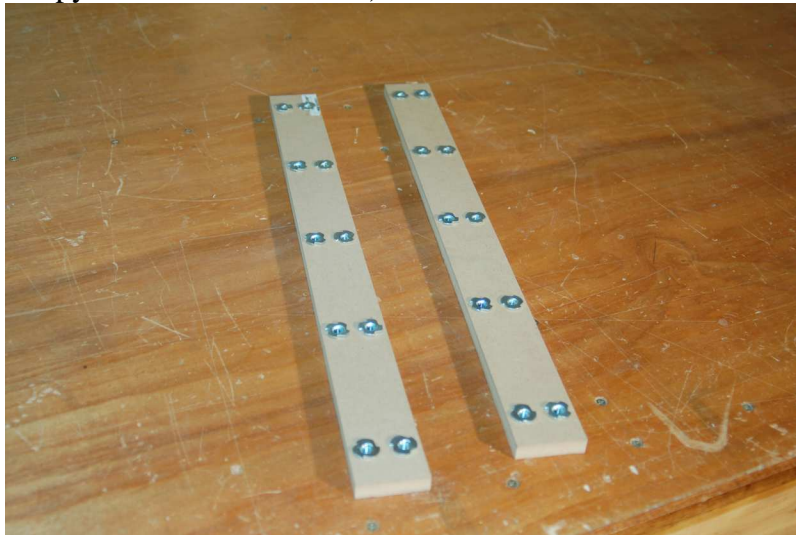

If you're building the canopy & windscreen option, it's ok to have drilled the top row of holes in both the end caps. You can still install the doubler in the front end cap and just attach it to the cap itself. You'll be shown this later on when we're working on the monitor deck.

Next up, you're going to have to countersink all the 1/4" mounting holes on both end caps as shown on the next page.

The Do it Yourself Cockpit Project – Series One

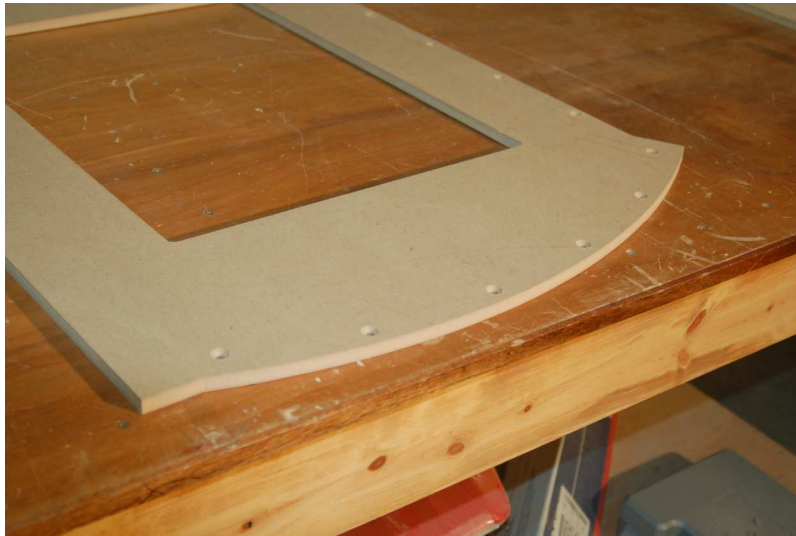

Now you need to get a couple of lengths of scrap material and use it to support the end cap, face up as shown:



This is done to allow the support to give you a little space under the part for the hinge screws to penetrate as well as to support the end cap door at the same height as the end cap itself.

The Do it Yourself Cockpit Project – Series One

Now you want to set the end cap door in place and then put 1/8" spacers all around it to ensure that the door will remain centered in the opening while you install the two hinges:



Next, you want to place the hinges 1-1/4" from the top and bottom edges of the door opening. Make sure that the end of the hinge that the pin is removed from is pointing to the top of the end cap as shown below:



The Do it Yourself Cockpit Project – Series One

I recommend using a self-centering pilot hole bit to drill the holes for the hinges. The one I used is from Rockler and is called a 5/64” Insty-Drive Self Centering HSS Drill Bit for #4 wood screws. The reason I used this is that the self-centering aspect of the tool ensures that the pilot hole will be placed in the center of the hinge mounting hole. This will prevent the flat head mounting screw from shifting the hinge away from where you wanted it as would happen if the hole was drilled off-center from the hinge mounting hole. When you’re done, the hinge installation should look something like this:



Now it’s time to carefully remove the spacing blocks from around the door and flip the end cap face down. The next step will be to install the magnetic door catch.



The door catch is just a simple magnetic latch that you can find at pretty much any hardware store. Cut a scrap of material roughly an inch wide by 3/4” high and long enough to support the magnet assembly as shown above.

The Do it Yourself Cockpit Project – Series One

Attach the mounting block to the back side of the end cap, right about the middle of the door. I used both glue and a couple of 1" 18ga pins:

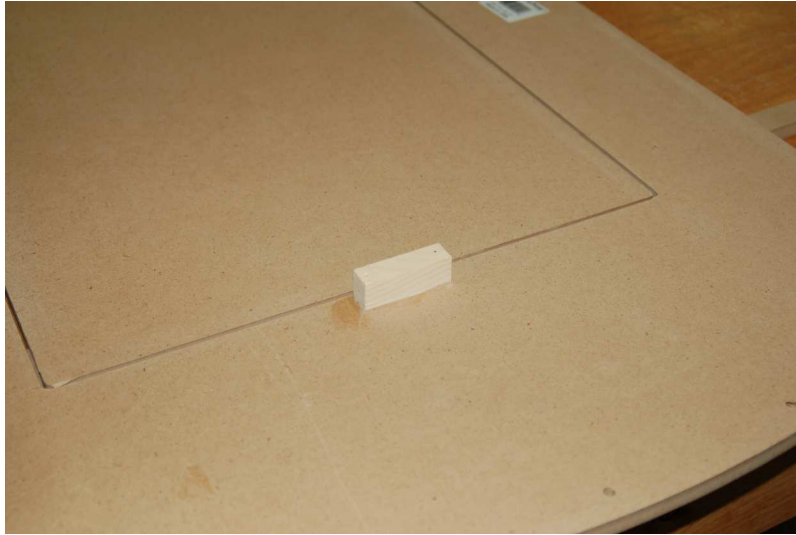

Now install the metal plate on the door itself. After you've done this, set the magnet assembly on the metal plate and screw it into the mounting block as shown below:



The Do it Yourself Cockpit Project – Series One

The next thing you're going to want to do is take down the sharp points of the screws that you used to mount the hinges. They're going to be sticking up just a little bit proud of the surface. A careful pass with a die grinder or a metal file will take care of this quickly:

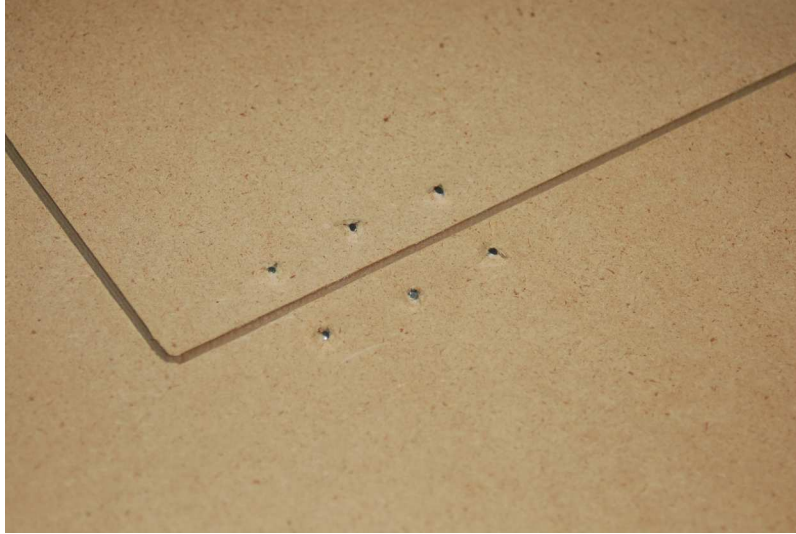

All you have left to do is install whatever knob or handle that you'd like to use and you're done!



In the next chapter, I'll cover assembling the cockpit for those that are not going to build the windscreen and canopy option. Don't skip the next chapter if you are going to build that option however. I'm only going to cover the major assembly step once. ☺

Chapter Thirteen

Assembling the Cockpit

Assembling the cockpit out of the sub-components is very easy. Everything bolts together and providing you've been careful during the build, the parts should like up correctly. The sides may deform during construction, but as you assemble the cockpit, any deformation can be pulled straight quite easily.

First off, collect up all the bits you've built:



You're going to start off by attaching the sides to the center core. If you've got a friend that can help you with this, the task will be much easier and you won't accidentally damage a side while bolting it together.

The Do it Yourself Cockpit Project – Series One

Each side requires 5 3.5" long 1/4" bolts.



As you can see here, I'm supporting the outside edge of the side with a chair. Silly, but it works if you're by yourself. I still recommend getting a friend to help. Remember back when you pre-drilled those holes? This is where that becomes critical. Make sure all your holes line up properly before you start tightening things down.



The Do it Yourself Cockpit Project – Series One



Now lay down a blanket of some kind to protect the cockpit side, and roll it over to install the other side. Please pay careful attention to how things floor lines up with respect to height and end-to-end alignment.



The Do it Yourself Cockpit Project – Series One

Now you need to install the end caps. Each one uses 12 1" long, 1/4" flat head screws:



You'll need three arms or a friend to help with this. Alternately, you can cheat by using a clamp to hold one side on while you thread screws into the holes on the other side. ☺

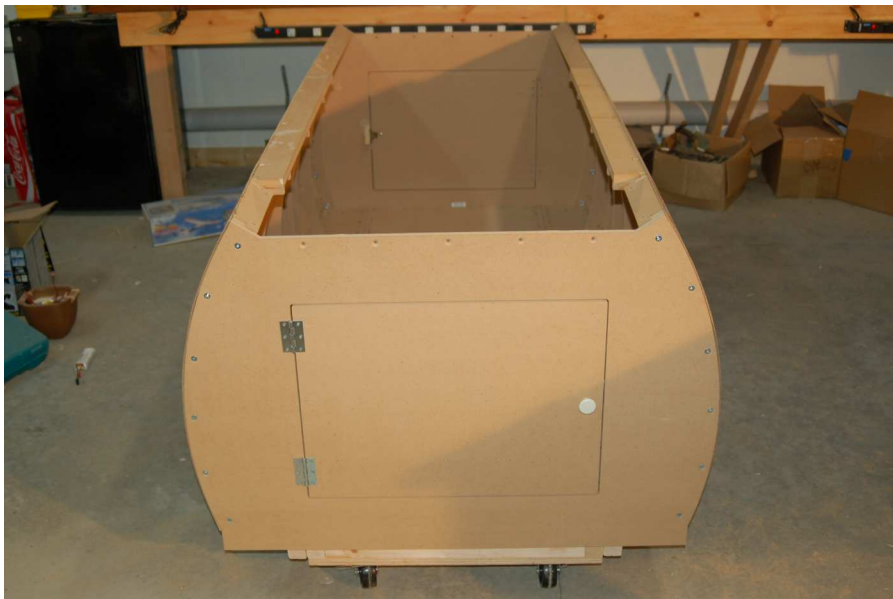

The end caps add quite a bit of strength to the cockpit once they're installed. You'll notice ongoing stiffening of the frame as you add parts. This of course, is a Good Thing™. ☺

The Do it Yourself Cockpit Project – Series One

Next you're going to install the aft cockpit arch. The first thing I want you to do though is to drill out and install a 1/4-20 t-nut in the top center holes of the arch assembly:

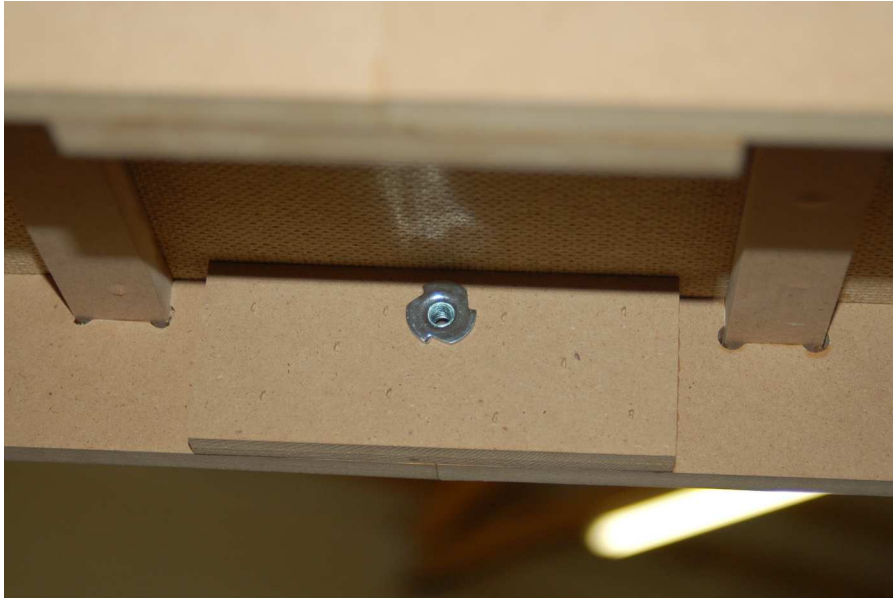

You'll need two 2" x 1/4" flat head screws for these two places. The rest of the screws are 1" x 1/4" flat heads.

The aft arch is installed using four 1" x 1/4" hex head bolts:



As tempting as it is, do NOT use the arch as a "handle" to move the cockpit around. By itself the mounting isn't strong enough to handle the stress. You'll just tear off the arch, leaving the two bottom stringers bolted into place. Trust me on this.

The Do it Yourself Cockpit Project – Series One

Here is the arch installed:



Now you're going to install the instrument panel support arch:



This part is installed using four 1" x 1/4" hex head bolts. If you have any bow-in or bow-out of the cockpit sides, they'll become immediately apparent at this point. Don't worry about it though – the instrument panel support arch will help correct any issue here.

The Do it Yourself Cockpit Project – Series One

Next up is the forward deck:



Like the instrument panel arch, this assembly will help correct any deformation issues in the side sections. You'll use four 1" x ¼" hex head bolts to install this part.

Now install the forward deck face:



You'll need 10 1" x ¼" flat head screws for this.

The Do it Yourself Cockpit Project – Series One

Ok, now you need to install the front and back caps on the aft cockpit arch:



This takes 10 1" $\frac{1}{4}$ " flat head screws and one 2" x $\frac{1}{4}$ " flat head screw.

The Do it Yourself Cockpit Project – Series One



The back face of the arch requires 15 1" x 1/4" flat head screws and one 2" x 1/4" flat head screw. Once this is attached, you can use the aft arch to move the cockpit around without worrying about it coming off. ☺

The Do it Yourself Cockpit Project – Series One

Last on the list is the instrument panel!



If you're not planning on building the windscreen & canopy, you're done with the rough construction of your cockpit. How you finish it is up to you and I would really like to have pictures of your project as you work on it! Work In Progress pictures and support questions can be posted to the DIY Cockpit Forum at <http://www.simpits.org/forum>.

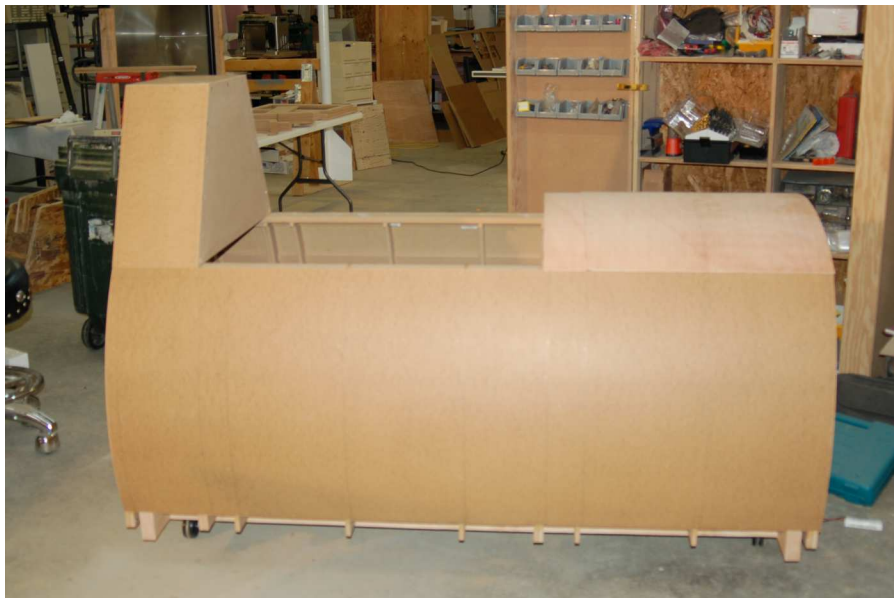

The Do it Yourself Cockpit Project – Series One

Appendix A – Reference Drawings

Right Cockpit Side – Parts Arrangement

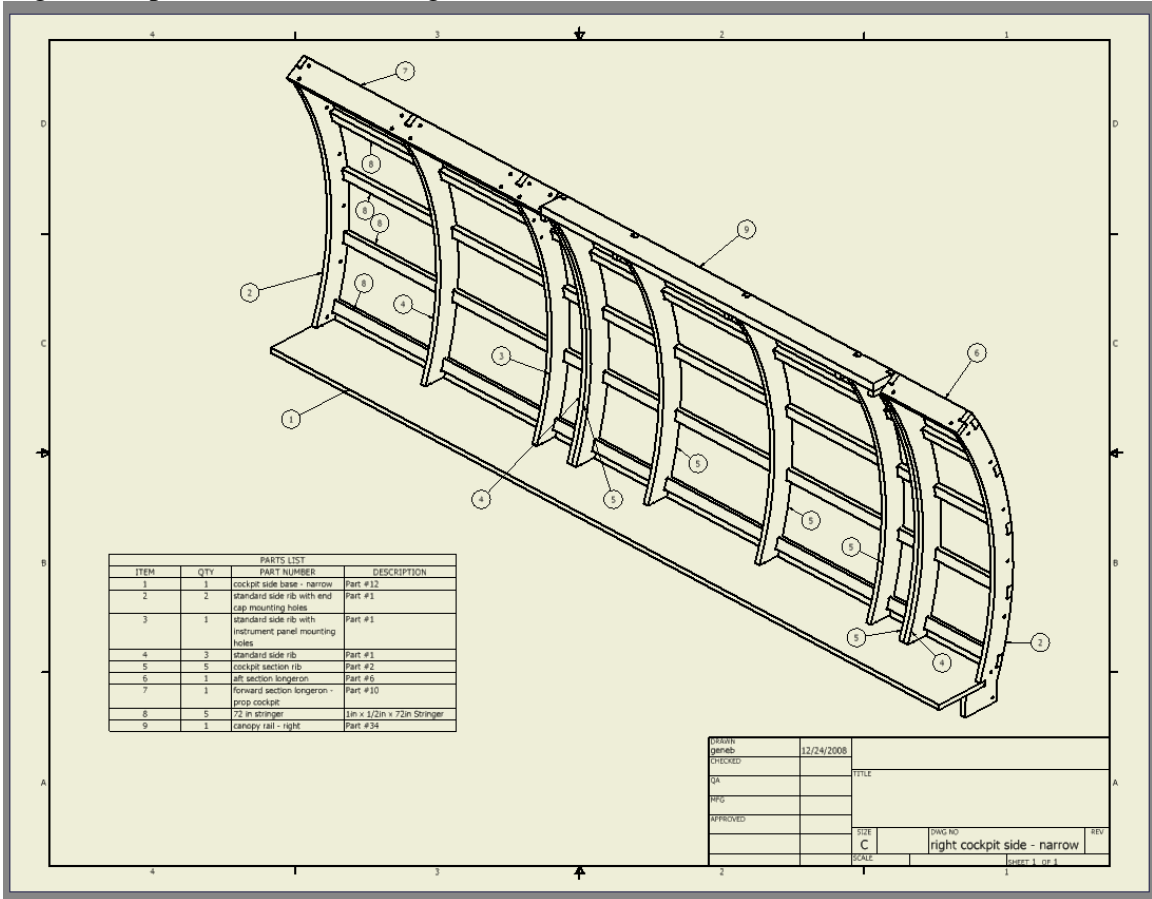

The Do it Yourself Cockpit Project – Series One

Left Cockpit Side – Parts Arrangement

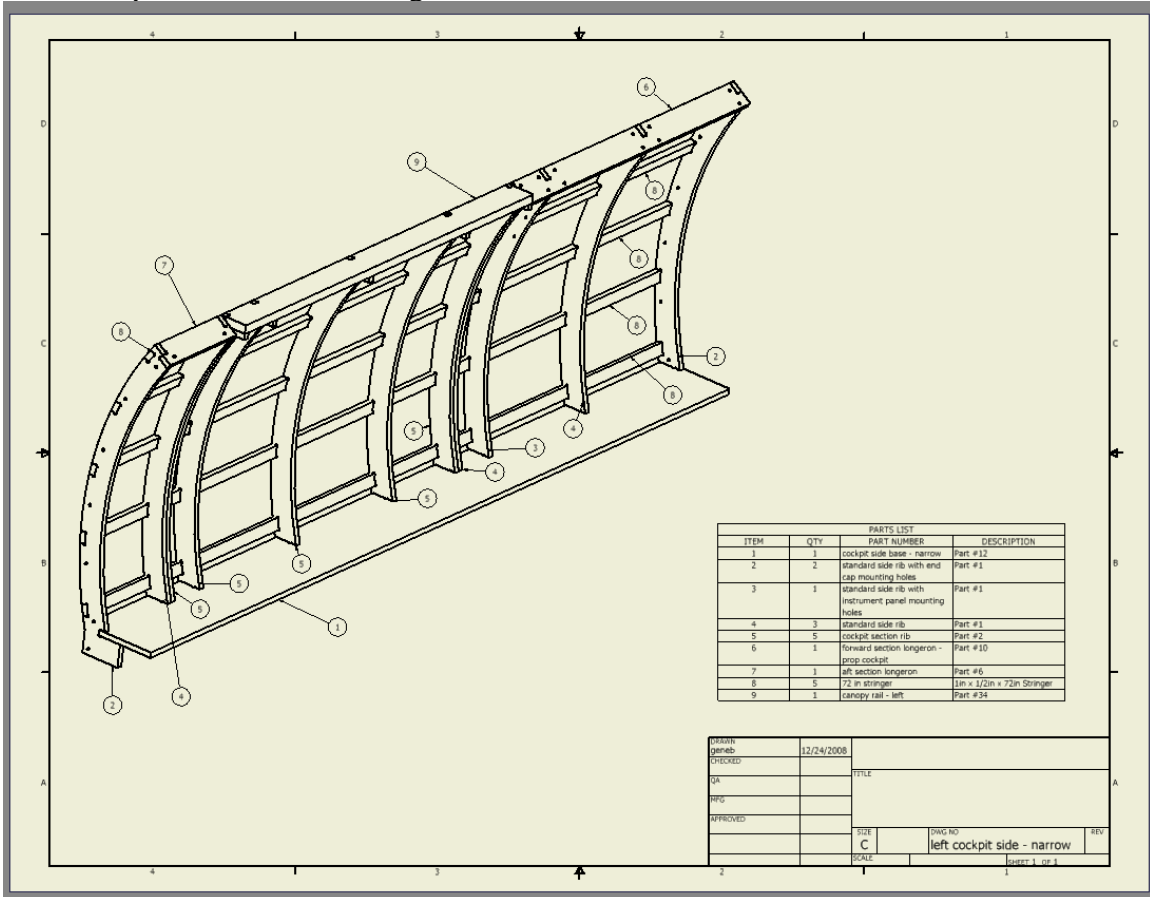

The Do it Yourself Cockpit Project – Series One

Forward Turtle Deck Parts Arrangement:

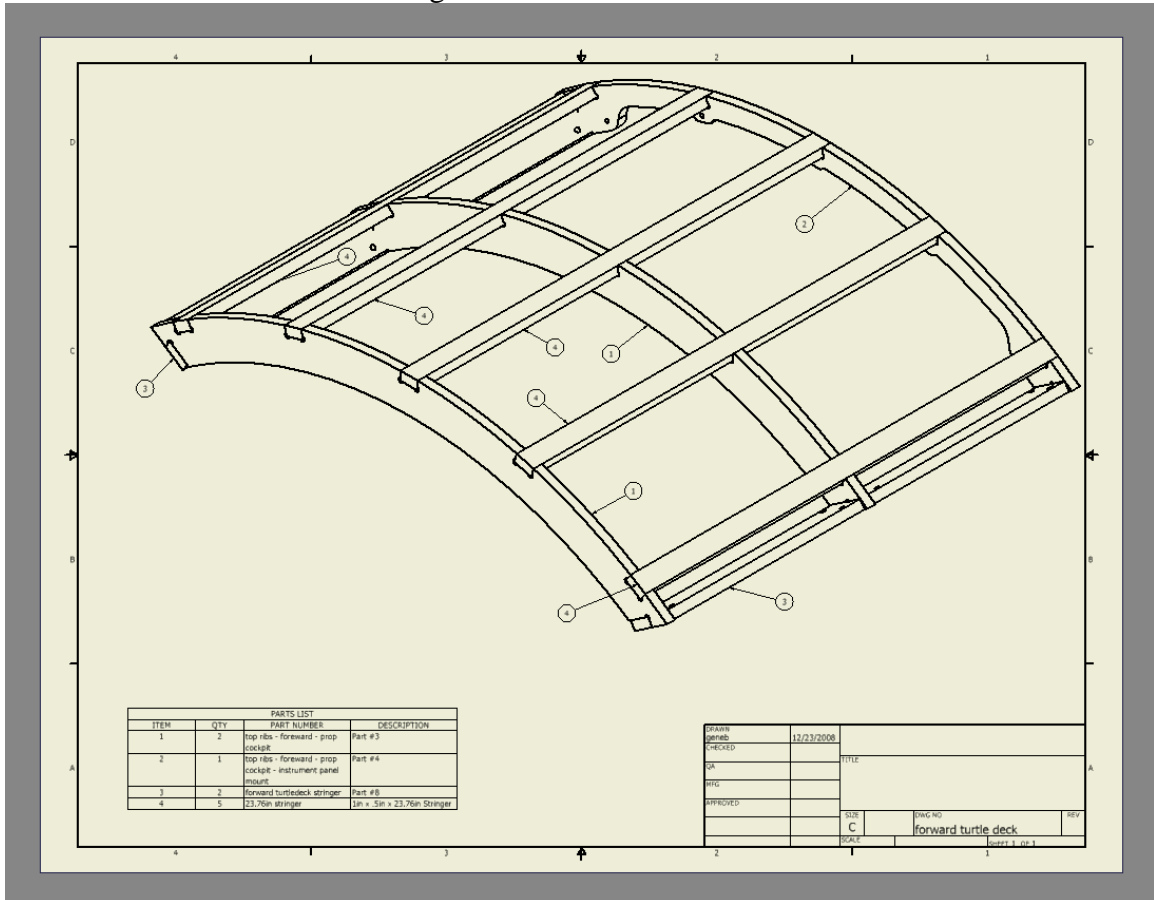

The Do it Yourself Cockpit Project – Series One

Instrument Panel Support Parts Arrangement

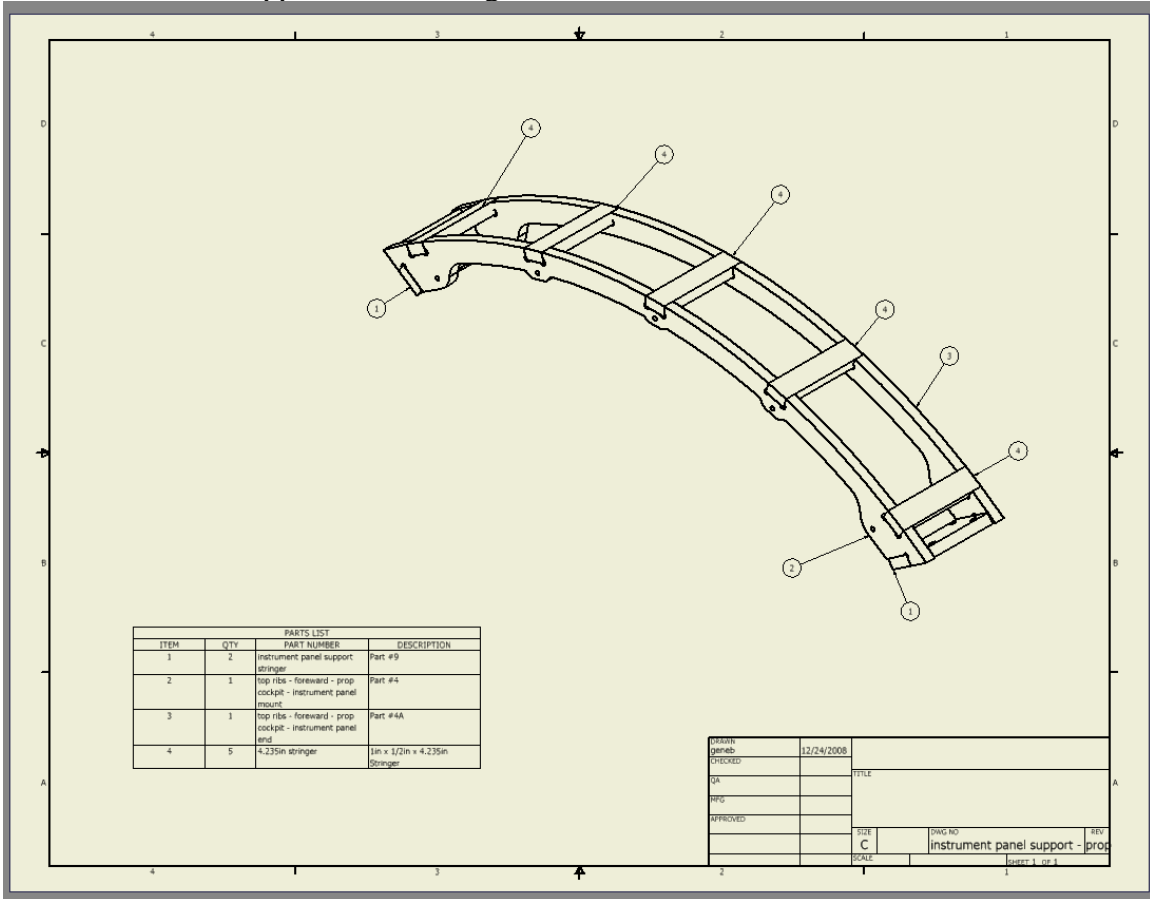

The Do it Yourself Cockpit Project – Series One

Aft Cockpit Arch, Squared – Parts Arrangement

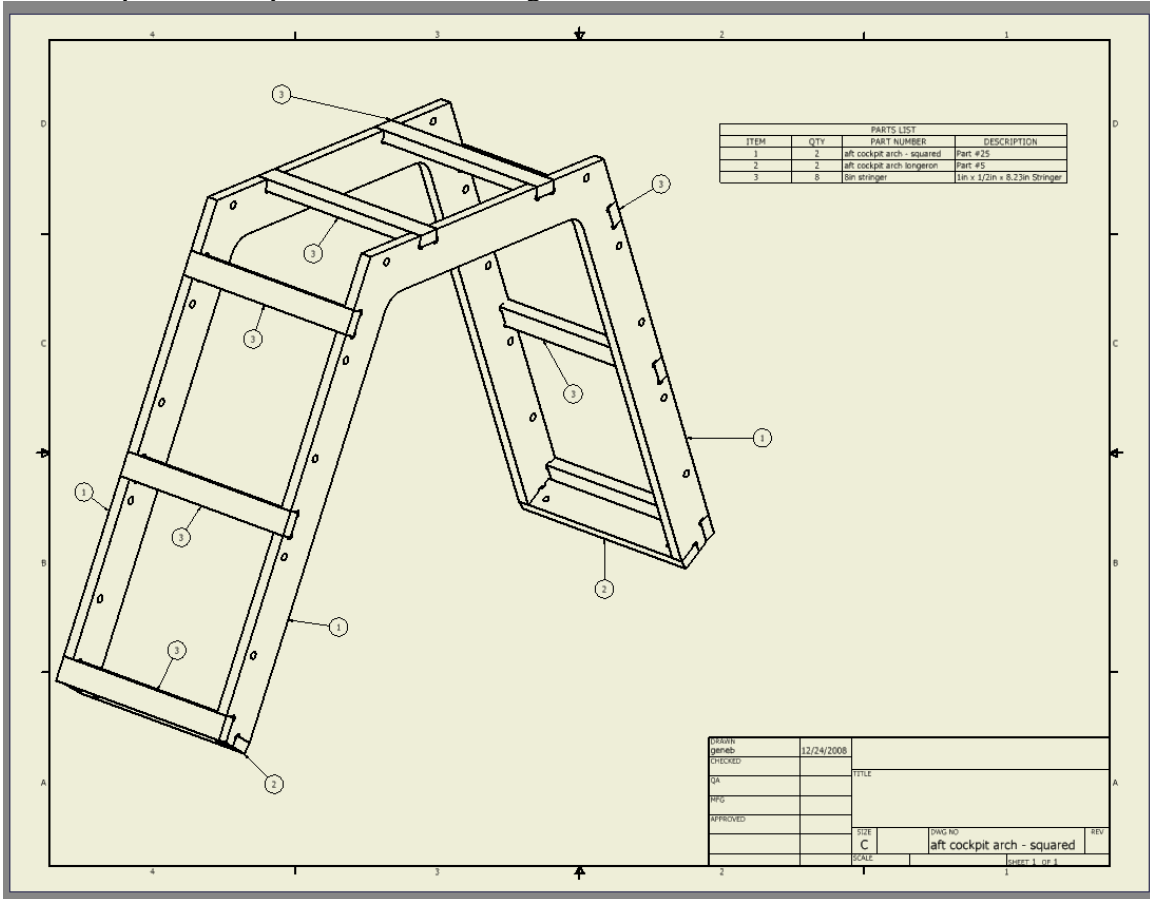

The Do it Yourself Cockpit Project – Series One

Aft Cockpit Arch, Rounded – Parts Arrangement

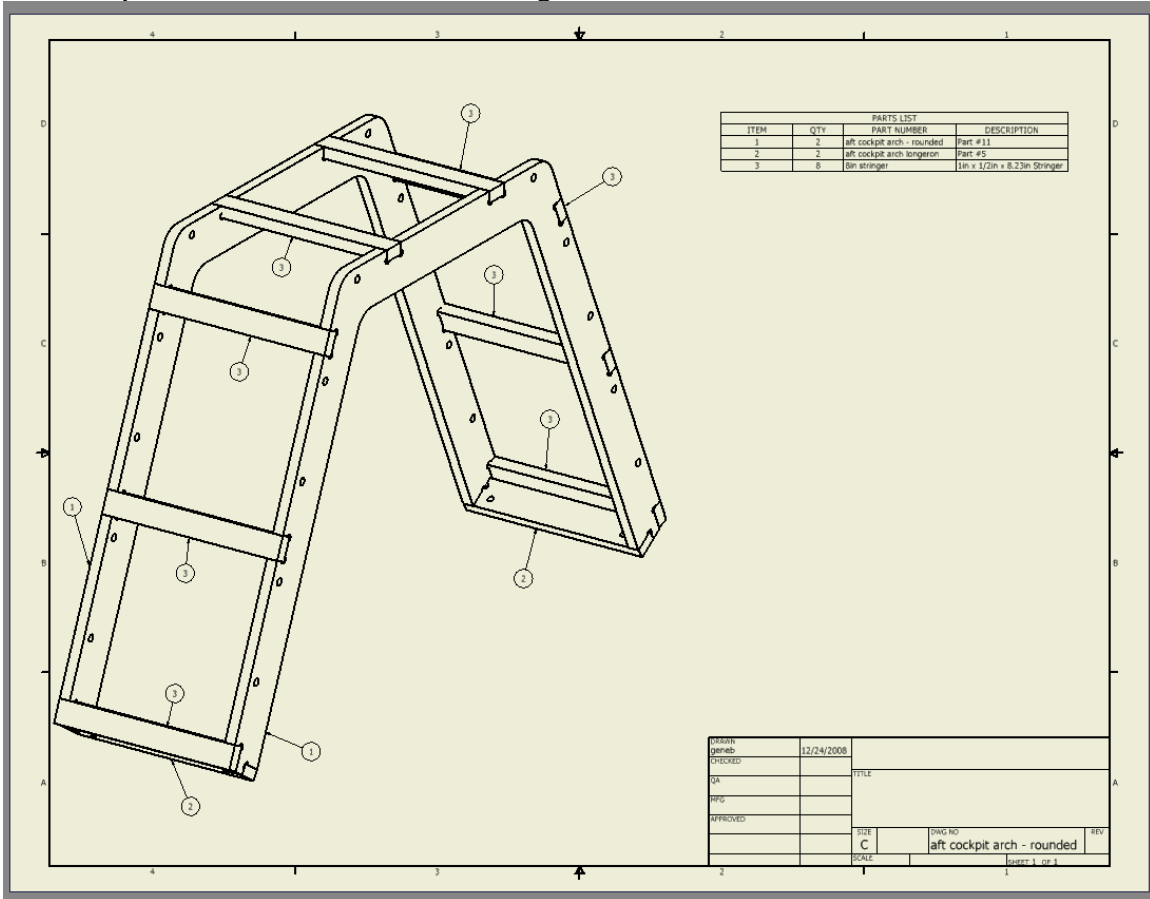

The Do it Yourself Cockpit Project – Series One

Aft End Cap – Rounded – Narrow – Parts Arrangement

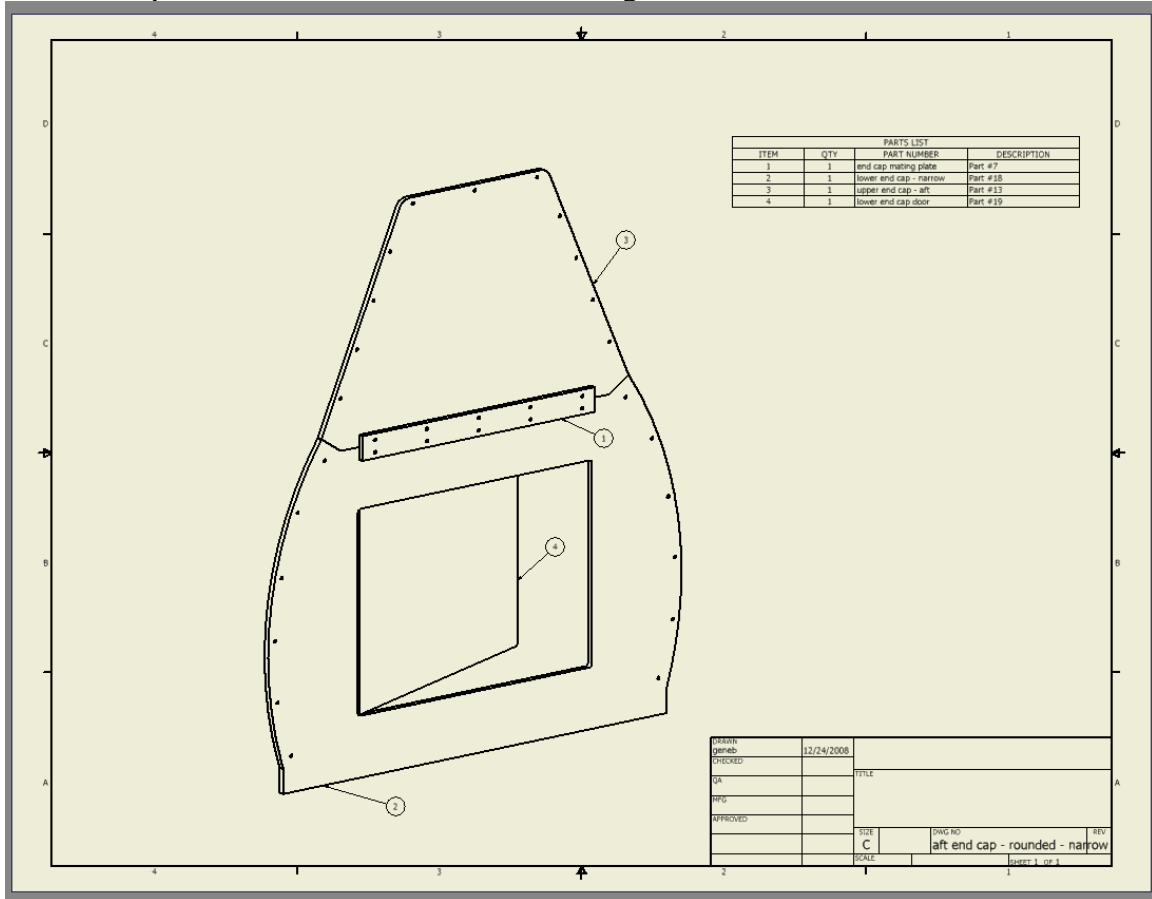

The Do it Yourself Cockpit Project – Series One

Aft End Cap – Squared – Narrow – Parts Arrangement

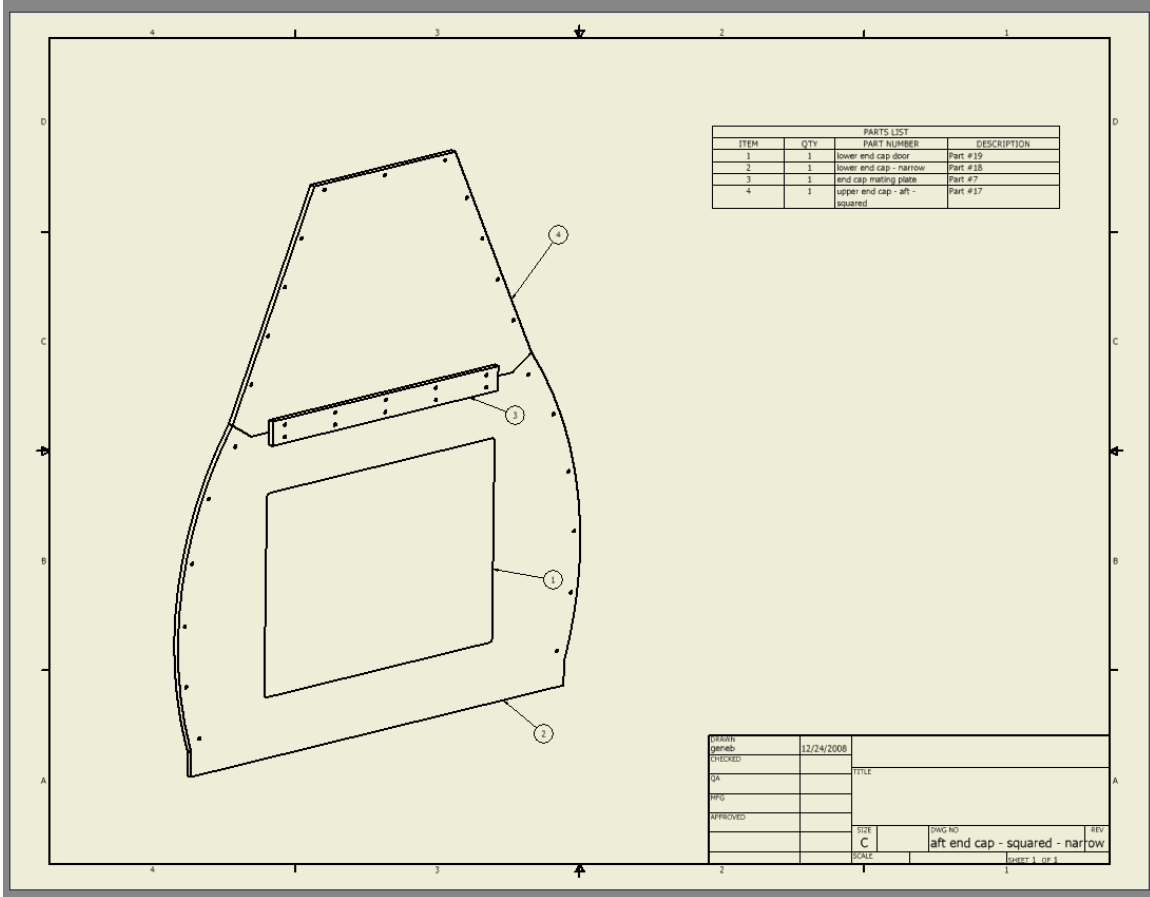

The Do it Yourself Cockpit Project – Series One

Windscreen – Parts Arrangement

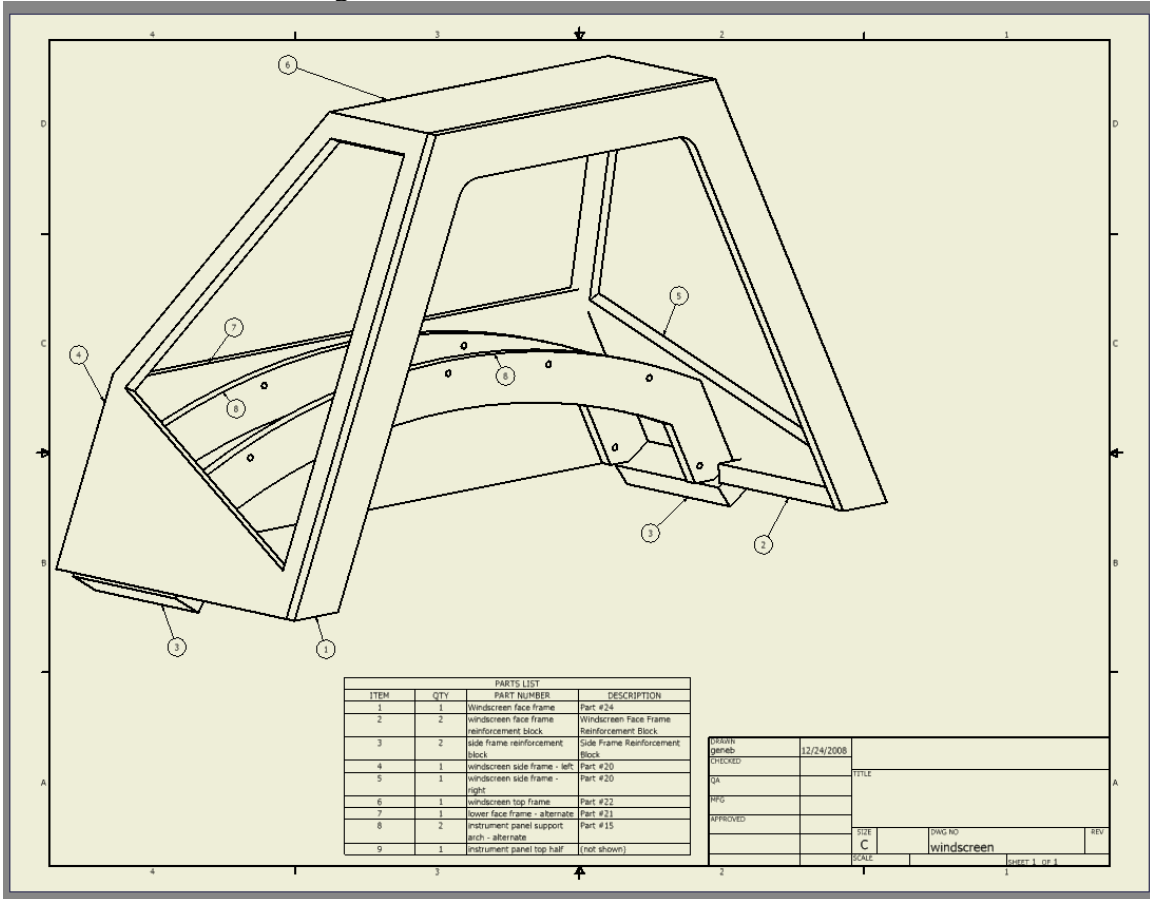

The Do it Yourself Cockpit Project – Series One

Monitor Deck – Parts Arrangement

